



S **LVENT SAVER** **RECYCLER**

INSTRUCTION MANUAL

STANDARD CAPACITY (SC) 3 GAL MODELS (1100 or 9711) &
HIGH CAPACITY (HC) 6 GAL MODELS (25000 or 9725)



- **Warranty**
- **Safety**
- **Operation**
- **Service Parts**
- **Troubleshooting Guide**
- **Contact Information**

TABLE OF CONTENTS

	<u>PAGE</u>
WARRANTY INFORMATION	4
SOLVENT RECYCLER LISTING CERTIFICATION.....	5-6
SOLVENT RECYCLER SPECIFICATIONS	7
SAFETY AND WARNING	8
General Safety	8
Danger and Warning Labels.....	8
General Safety Rules	9
Personal Safety.....	9
Unit Use and Care.....	10
Safety Rules.....	10-11
OPERATING PRINCIPLES OF THE DISTILLATION UNIT	12
GOALS	13 - 14
WARNING FOR THE DISTILLATION UNIT.....	15
PROTECTION OF THE NATURAL ENVIRONMENT	16
INSTALLATION	16
DISTILLER ELECTRICAL CONNECTIONS	17
KEYBOARD OPERATIONS	18
SELECTION BETWEEN CELSIUS AND FAHRENHEIT MODE.....	19- 21
STARTING PROCEDURES	22 - 23
SELECTING THE TEMPERATURE AND DURATION OF THE CYCLE.....	24
STARTING THE UNIT	25
DURING THE DISTILLATION CYCLE.....	26
AT THE END OF THE CYCLE.....	26

TABLE OF CONTENTS (cont'd)

	<u>PAGE</u>
CONTROL MODULE SELF-TESTING PROCEDURES	27
TEMPERATURE GUIDE - FLAMMABLE SOLVENTS	28
TEMPERATURE GUIDE - NON-FLAMMABLE CHLORINATED SOLVENTS.....	29
WARNING	29
THERMIC OIL CHANGING PROCEDURES	30
TROUBLESHOOTING GUIDE (Distillation at Atmospheric Pressure)	31 - 32
MAINTENANCE SCHEDULE	33
SCHEMATICS OF UNIT	34 - 38
SERVICE PART NUMBERS FOR RECYCLER	39 - 40
INSTALLATION CODE REQUIREMENTS	41
WARRANTY INFORMATION / TECHNICAL ASSISTANCE	42



LIMITED WARRANTY

Solvent Recyclers (3 & 6 Gallon) & Paint Gun Cleaners

24 MONTH LIMITED WARRANTY

BECCA Solvent Recyclers and Paint Gun Cleaners components are warranted to be free of defects in material or workmanship for 24 months from established purchase date to the original user or from original shipment whichever is sooner. During months 1 through 12 BECCA will repair or replace any component including labor that is found to be defective in material or workmanship as determined by BECCA factory certified service technician. For months 13 through 24 BECCA will furnish parts only (no travel, diagnostic or repair labor is provided) to replace any component that is found to be defective in material or workmanship as determined by BECCA factory certified service technician. In all cases defective parts shall be returned to BECCA for inspection and final approval.

There is no other express warranty, implied warranties, including those of merchantability and fitness for a particular purpose, are limited to one year from purchase and to the extent permitted by law any and all implied warranties are excluded. This is the exclusive remedy and liability for consequential and incidental damages under any and all warranties are excluded to the extent exclusion is permitted by law.

CONDITIONS OF WARRANTY

BECCA has no control over working conditions, solvents involved in usage and under which purchaser stores, handles or uses BECCA product. We make no warranty or condition, either expressed or implied with respects to usage or mistreatment of product. These warranties apply only to the original purchaser and do not apply if the unit has been misused, subjected to overloading, neglect, accident, altered or used for any other purpose. BECCA shall not be liable for loss, damage or delay due to, without limitation, acts of God, transportation delays, accident, fire, action of civil or military authority, adverse weather or any other causes beyond BECCA's control. This warranty does not cover transportation, interior or exterior finishes. The use of unauthorized chemicals or solvents with acid content in this unit shall render this warranty null and void. BECCA shall not be responsible or liable for any consequential or incidental damages, including without limitation, loss of production or faulty production, loss of use or loss of profit. Attempts at repair or alterations by the owner shall also constitute a violation of this warranty. Only BECCA certified personnel shall start-up, train, repair or alter BECCA equipment. Paint Gun Cleaner Brushes, Filters, and Plastic Gun Clips & Solvent Recycler Gaskets/Seals, Oil, and Bags are subject to be replaced due to normal usage, wear and tear within the warranty period and are excluded from this warranty.

These warranties replace all other warranties expressed or implied by nature or otherwise, and are not assignable or transferable from original purchaser.

Warranty is in effect after receipt of Registration information & full payment

2010 Cobb Intl Blvd Ste H Kennesaw, GA Phone 1-800-655-5649 Fax 1-800-655-5684

Revision 3/27/07



Certificate of Compliance

Certificate: 1683243 **Master Contract:** 230679
Project: 1730482 **Date Issued:** 2006/01/19
Issued to: BECCA, Inc.
2010 Cobb International Blvd NW
Suite H
Kennesaw, GA 30152
USA
Attention: Mr. Barry J. Thomas

The products listed below are eligible to bear the CSA Mark shown with adjacent indicators 'C' and 'US'



Issued by: Jean-Claude Chow, Eng.

Authorized by: Helene Vaillancourt, Manager,
Certification Services

PRODUCTS

CLASS 2878 02 - HEATERS - Miscellaneous - For Hazardous Locations
CLASS 2878 82 - HEATERS-Miscellaneous - For Hazardous Locations-Certified to U.S. Standards

Class I, Division 1, Group D, Temp code T2B-260°C

Solvent recyclers, permanently connected, stationary, Model 1100, rated 220V, 1 phase, 60Hz, 1.012kW, 4.5A;
Model 25000, 220V, 1 ph, 60Hz, 2.050kW, 9.0A.

Notes:

The 'C' and 'US' indicators adjacent to the CSA Mark signify that the product has been evaluated to the applicable CSA and ANSI/UL Standards, for use in Canada and the U.S., respectively. This 'US' indicator includes products eligible to bear the 'NRTL' indicator. NRTL, i.e. National Recognized Testing Laboratory, is a designation granted by the U.S. Occupational Safety and Health Administration (OSHA) to laboratories which have been recognized to perform certification to U.S. Standards.



Certificate: 1683243

Master Contract: 230679

Project: 1730482

Date Issued: 2006/01/19

1. Final acceptance of the installation subject to local inspection authorities having jurisdiction
2. For use per Manufacturer's Instruction Manual, for mounting clearances, appropriate deposit bag, and conditions of use.

APPLICABLE REQUIREMENTS

CSA-C22.2 No. 30-M1986 - Explosion-Proof Enclosures for Use in Class I Hazardous Locations

CAN/CSA-C22.2 No. 157-92 - Intrinsically Safe and Non-Incendive Equipment for Use in Hazardous Locations

UL Std. No. 823 (8th Edition) - Electric Heaters for Use in Hazardous (Classified) Locations

UL Std. No. 674 (3rd Edition) - Electric Motors and Generators for Use in Hazardous Locations Class I, Groups C and D; Class II, Groups E, F and G

UL Std. No. 2208 (1st Edition) - Solvent Distillation Units

SOLVENT RECYCLER SPECIFICATIONS

SPECIFICATIONS

US Units

Metric Units

	U.S. Units	Metric Units	U.S. Units	Metric Units
Geometrical capacity of boiler	4 Gallons	16 Liters	8 Gallons	32 Liters
Useful capacity of boiler	3 Gallons	11 Liters	6 Gallons	25 Liters
Operating temperature	104°-392°F	40°-200°C	104°-392°F	40°-200°C

Solvent protection	Class I, Div. 1, Group D		Class I, Div. 1, Group D	
Solvent temperature class	T2B – 260°C		T2B – 260°C	
Absolute operating pressure	{ 223 – 1,000 hPa 170 – 760 mmHg -0.223 – 1 bar		223 – 1,000 hPa 170 – 760 mmHg -0.223 – 1 bar	
Relative operating pressure	{ -776 – 0 hPa -590 – 0 mmHg -0.776 – 0 bar		-776 – 0 hPa -590 – 0 mmHg -0.776 – 0 bar	
Time per cycle of distillation	3.5 – 4.5 Hours (estimate)		3.5 – 4.5 Hours (estimate)	
Yield	85% – 97%		85% – 97%	
Cooling system	Fan Cooled		Fan Cooled	
Boiler material	Stainless steel AISI 304		Stainless steel AISI 304	
Cover material	Stainless steel AISI 304		Stainless steel AISI 304	
Condenser material	Copper (standard) / Stainless steel (optional)		Copper (standard) / Stainless steel (optional)	
Voltage	220 V – 1 ph		220 V – 1 ph	
Absorbed power	1,056 W		2,056 W	
Amperage	4.5 amps		9.5 amps	
Thermic oil reservoir capacity Prior to October 2005	2 Gallons	7 Liters	3 Gallons	11 Liters
Thermic oil reservoir capacity After Oct 2005 to Present	2.25 Gallons	8.5 Liters	3.25 Gallons	12.3 Liters
Dimensions (in inches)	33" length x 26" depth x 43" height		33" length x 26" depth x 43" height	
Weight	240 Lbs.	109 Kg	260 Lbs.	118 Kg
Transfer Valve -GW to Recyc	standard		standard	
Groundable Container	1 (not included)		1 (not included)	
Warranty	24 months		24 months	

SAFETY AND WARNING

GENERAL SAFETY

1. Carefully inspect the shipping carton for any signs of transport damage. The damage to the carton often indicates possibility of transport damage to the equipment inside.
2. Carefully remove your Becca Solvent Recycler from the shipping carton.
3. Check your equipment immediately to ensure that it is free of transport damage. Report any transport damage to the carrier without delay for possible claim procedures. Becca Recycling Technologies Inc. is not responsible for damage to equipment after it leaves our warehouse.
4. Check the equipment list and compare it with the parts you have received. If any parts are missing, contact the supplier you purchased the equipment from.
5. This unit is intended for use in Painting and Refinishing Operations in Body Shops and Industrial Facilities. This unit has not been reviewed for use in a laboratory, dry cleaning facilities, aircraft hangers, commercial garages, or service stations.

Before operating the BECCA SOLVENT RECYCLER, read this Instruction Manual completely. All BECCA products are engineered and manufactured to the highest performance standards and have been subjected to detail testing before shipment from the factory.

DANGER AND WARNING LABELS

DANGER



1



2



3



4

WARNING



5



6



7



8

1. Presence of flammable vapors and solvents.
2. No smoking or metal grinding nearby.
3. Keep away from open flames.
4. Wear Breathable Air during use.
5. Observe warnings at all times.
6. Read the Instruction Manual carefully.
7. Wear solvent-proof rubber gloves.
8. Wear protective eyewear before use.

SAFETY AND WARNING (cont'd)

WARNING

« READ ALL INSTRUCTIONS » Failure to follow the SAFETY RULES identified by a BULLET (°) symbol listed BELOW and other safety precautions may result in serious personal injury.
« SAVE THESE INSTRUCTIONS »

GENERAL SAFETY RULES

- **KEEP WORK AREA CLEAN.**
- **KEEP CHILDREN AWAY.** Do not let visitors come in contact with the equipment. All visitors should be kept away from the work area.

PERSONAL SAFETY

- **GUARD AGAINST ELECTRIC SHOCK.** Prevent body contact with grounded surfaces, for example: pipes, radiators. Solvent resisting rubber gloves and non-skid footwear is recommended where damp or wet ground may be encountered. A ground fault circuit interrupter protected power line must be used for these conditions.
- **DRESS PROPERLY.** Do not wear loose clothing or jewelry. They can be caught in the moving parts. Wear protective hair covering to contain long hair.
- **USE SAFETY EQUIPMENT. WEAR SAFETY GOGGLES** or glasses with side shields.
- **STAY ALERT. USE YOUR COMMON SENSE.** Concentrate on what you are doing. Do not operate the unit when you are tired or under the influence of drugs.
- **DO NOT OVERREACH.** Keep proper footing and balance at all times.
- **BEFORE CONNECTING THE UNIT** to an electric line outlet, be sure the power is the same as that specified on the nameplate of the Solvent Recycler. An electric line with power greater than that specified on the Solvent Recycler can seriously injure the user – as well as damage the Solvent Recycler. If in doubt, DO NOT plug in the unit. Using an electric line outlet with power less than the power specified on the nameplate is harmful to the motor.

SAFETY AND WARNING (cont'd)

UNIT USE AND CARE

- **DO NOT PROCESS NITROCELLULOSE - Nitrocellulose** which is an ester of cellulose and nitric acid cannot be recycled. It automatically **ignites** at 275°-330°F (135°-166°C) and can be extremely volatile.
- **DO NOT FORCE THE UNIT.** It will perform better and safer at the rate for which it was designed.
- **THE USE OF ANY OTHER ACCESSORIES** not specified in this manual may create a hazard.
- **DISCONNECT THE UNIT**, before servicing.
- **DO NOT ALTER OR MISUSE THE UNIT.** These units are precision built. Any alteration or modification not specified is misuse and may result in a dangerous situation.

Only trained repairmen should attempt (°) ALL REPAIRS, electrical or mechanical. Contact the nearest Becca repair service facility. Use only Becca replacement parts, any other parts may create a hazard.

SAFETY RULES

- **THE OPERATOR MUST WEAR** protective solvent-proof rubber gloves to prevent contact between his hands and the products used for washing.
- **THE OPERATOR MUST WEAR** protective eyewear to prevent spatter from coming in contact with his eyes.
- **STAY ALERT** at all times. Make sure the solvent is not «corrosive». Immediately stop the recycler and replace the solvent whenever you note signs of corrosion on the unit.
- **IF EYES COME IN CONTACT WITH SOLVENTS** rinse thoroughly with water.
- **BEFORE USING** the Solvent Recycler, make sure that all safety devices are in perfect operating condition.
- **REVIEW THE CONTROLS** and their functions before commencing work.
- **USE GROUNDABLE CONTAINERS (Containers, solvents are supplied in, are recommended)** for the collection of solvents.
- **BE CAREFUL** when you load or unload the solvent in the unit. Make sure you do not splash or spill the contents on the workshop floor.
- **THE OPERATOR MUST PERIODICALLY** check the level of the clean solvent contained in the collection pail to prevent it from overflowing.

SAFETY AND WARNING (cont'd)

- **DO NOT USE ELECTRICAL OR PNEUMATICAL TOOLS WITH THE UNIT. AVOID GASEOUS AREAS.** Do not operate portable electric tools in explosive atmospheres in the presence of flammable liquids or gases. Motors in these tools normally spark, and do not scrape or scratch the machine with metal objects; the sparks might ignite fumes.
- **DO NOT ALLOW FAMILIARITY GAINED FROM FREQUENT USE OF YOUR SOLVENT RECYCLER TO BECOME COMMONPLACE.** Always remember that a careless fraction of a second is sufficient to inflict severe injury.
- **DO NOT ALTER OR MISUSE THE UNIT.** Any alteration or modifications is a misuse and may result in serious personal injuries.
- **FIRE EXTINGUISHING SYSTEMS** must be installed in the same room or close to the unit in case of emergency. These appliances must be kept efficient and inspected every year by a certified person.
- **THE INSTALLATION SITE MUST PERMIT PERSONNEL TO EASILY AND QUICKLY MOVE AWAY FROM DANGER ZONES IN CASE OF AN EMERGENCY.**
- **DO NOT USE THE UNIT TO** wash or degrease objects designed to come in contact with food.
- **COMPLY WITH LAWS IN THE COUNTRY** where the Solvent Recycler is installed regarding the use and disposal of the products used to wash clean objects.

THINK SAFETY! SAFETY IS A COMBINATION OF THE OPERATOR'S COMMON SENSE, KNOWLEDGE OF THE SAFETY AND OPERATING INSTRUCTIONS AND ALERTNESS AT ALL TIMES WHEN THE UNIT IS BEING USED.

OPERATING PRINCIPLES OF THE DISTILLATION UNIT

This solvent recycler will recycle many different types of solvents that have been contaminated by paints, pigments, inks, greases, oils, etc. Through the simple distillation process, the distiller separates the contaminants from the original solvent.

The boiling of the polluted solvents consists of a boiler surrounded by a reservoir containing thermal oil, heated by an electrical resistance. The solvent vapors produced in the boiler are eventually conveyed in an air-cooled condenser and then brought back to their liquid state. The cooled solvent is gathered in a clean collecting tank, ready to be re-used again. The process does not alter the characteristics of the distilled solvent. Consequently, the operation can be performed endlessly.

The residues remain inside the boiler and can be unloaded when cold. It is required to use a **BECCA liner bag (Part #630003 for Model 9711 and Part #660006 for Model 9725**, for information contact the authorized reseller) to be placed inside the boiler. These bags facilitate the unloading of residues at the end of the distillation cycle.

The cycle is completely automatic. The operator only has to fill the boiler with dirty solvents, close the lid, touch the **START** button and remove the residues at the end of the cycle.

In case of malfunction, abnormal increase of temperature or power failure, the cycle is automatically **STOPPED** and the recycler **CANNOT** be re-started until the problem has been resolved.

GOALS

The goals that can be achieved with BECCA distillation units are:

1. Solvent recycling with the highest yield possible.
2. Obtaining "special" and not "toxic and noxious" residues.
3. Reducing intervention times and operator discomforts.

As "**Solvent / Contamination product**" topologies are so different that there is no such rule valid for all cases, we will try to summarize providing general information that may be useful to you. Experience will later on help you find the most adequate method of meeting your requirements.

GOALS (cont'd)

The products to be recycled normally consist of:

Solvent or Reducer + Contaminated Products

- **Solvent**

"Solvent" defines the liquid, which, without reacting chemically, dissolves other substances (solutes), forming a solution.

As every solvent has its own boiling temperature, we must (in order to distill the solvents) set the thermostat at a higher working temperature of about 80°F (30°C) than the boiling point.

- **Reducer**

A mixture of solvent is defined as a "reducer".

As every solvent component in the mixture has its own boiling temperature, in order to proceed to the distillation of a reducer, set the thermostat at a working temperature of about 80°F (30°C) higher than the boiling point of the most high-boiling solvent.

- **Chlorinated Solvents**

Chlorinated Solvents are **non-flammable** solvents, generally utilized for cleaning and degreasing metal surfaces. Normally, these types of solvents are polluted by **oil, grease**, etc.

Atmospheric pressure distillation of chlorinated solvents will result in a partial recovery, leaving a distillation residue containing about 20% of solvents. This occurs when the oil contents in the boiling solution increases; therefore the mixture distillation temperature rises.

These solvents are thermalable, meaning that when they exceed their specific critical temperature they decompose causing the formation of hydrochloric acid. This acidifies the product and therefore **cannot** be re-used.

When operating with atmospheric pressure, and reaching this critical temperature, we shall have distilled only 80% of the solvent.

Operating with a vacuum will allow you to achieve a yield of 100%, as you do not reach the critical temperature (vacuum kit is optional).

GOALS (cont'd)

- **Liquid Polluting Products**

The most common liquid contamination products are:

Oil, Ink and Water

The presence of liquid contamination may (in the distillation phase) drag contaminants into the clean product, leaving traces in the distillate.

For different types of oil and ink with particularly high boiling temperature, this problem normally does not occur and the process of separation may be obtained with a simple distillation.

If there is "**water**" in the contaminated product, you **must recycle** with a **fractional distillation**. This operation is not possible with a simple distillation process.

Unloading a liquid polluting product from the distiller presents no problem. It is possible to obtain a complete separation of the polluting product from the reducer.

This complete separation is not possible when **Chlorinated Solvents** are to be distilled under atmospheric pressure.

For these solvents it is necessary to proceed with a "**vacuum**" distillation. This process allows you to obtain a residue without solvent.

- **Solid Polluting Products**

The most common solid polluting products are:

Resins, Pigments, Paints, Polymers, Glue, Powder, Grease, etc.

Solid polluting products, according to their nature, already classified as "**toxic and noxious**" have the advantage (in comparison to liquid contamination products). They can be unloaded into controlled waste dumps, as they do not release toxic substances into the ground. However, this is on the condition that the percentage of solvent will not exceed that of the Concentration Limit (CL) – a value legally stabilized for different types of solvents used in different Countries.

By distillation, and this is another considerable advantage, you can obtain an extremely pure distilled product as there will be no contaminants dragged into the distilled product.

The disadvantage, in comparison with liquid polluting products, is a greater difficulty in cleaning the distillation unit.

Leave a minimal percentage of solvent (3-10%) with the contaminants in the solution of residue, in order to obtain a semi-solid residue, and therefore will be easily discharged.

These percentages, however, are greater than the Concentration Limit (CL) accepted for the disposal in controlled dumps.

WARNING FOR THE DISTILLATION UNIT

The operating staff must be fully instructed on the use and function of the unit as well as on the correct application of the protection devices. The instructions must be repeated in regular intervals.

It is essential to keep the Instruction Manual inside the door slot or close to the unit.

Operator must wear anti-static clothes, avoiding clothes made of synthetic material (nylon, rayon, etc.).

Use groundable containers (Containers, solvents are supplied in, are recommended) for the collection of solvents

Open the cover only after the unit has cooled down, at less than 212°F (100°C).

When unloading residues, it is recommended to use gloves and an anti-vapor mask.

Do not use any metallic tools as they could provoke sparks.

The unit must undergo a revision and control according to its grade of use. Maintenance must be carried out by qualified personnel and according to the indications of the Manufacturer.

It is important to pay attention to the control of the security installations: thermostats, flow controls, thermocouple detectors, switches of safety levels, aspirators, etc.

Before using a distillation unit, which has been out of use for a long time, it must be checked and brought back into optimal condition in order to guarantee the operator's security at all times.

According to the type of liquid to be distilled and the kind of operation to be performed, it is important to adopt adequate personal protection rules.

If you are not using plastic bags, the residues must be cleaned with tools that do not provoke sparks.

The cover works as a safety valve. If you notice steam leaking from the cover, immediately shut down the recycler and consult page 29, "**Defects, Causes and Remedies**". In any case, never modify in any way the parts on top of the cover or block the cover in order to avoid the steam from leaking.

Nitrocellulose which is an ester of cellulose and nitric acid and is a component in many lacquers, inks, adhesives and cements cannot be recycled. It automatically **ignites** at 275°-330°F (135°-166°C) and can be extremely volatile.

It is important to clean the boiler thoroughly after each cycle, as a build up of residue will stop the transmission of heat and cause a malfunction.

If repairs are necessary shut off the power supply **IMMEDIATELY**.

Do not smoke, cause sparks or use open flames near the recycler.

WARNING FOR THE DISTILLATION UNIT (cont'd)

This unit is for use in a 104°F (40°C) environment with no forced ventilation. Under these conditions, the unit shall be spaced a minimum of 5 feet (1.5 meters) from potential sources of ignition such as electrical receptacles, switches, pilot light fixtures, contacts and other similar equipment that can produce sparks. If the equipment is used in higher ambient temperatures an increase in spacing from sources of ignition shall be considered.

This unit has been tested for use with the solvents indicated in the Instruction Manual (see tables on pages 26-27, "**Flammable Solvents and Non-Flammable Chlorinated Solvents**").

PROTECTION OF THE NATURAL ENVIRONMENT

The user must provide protection of the environment so that the recycler may not be the cause for emission of vapors or odors and that the residues are treated and disposed of in a correct way.

INSTALLATION

Placing your BECCA SOLVENT RECOVERY SYSTEM in accordance with the following procedures and the BECCA General Arrangement Drawing.

The unit (if not installed in open air) must be installed in a location with sufficient natural or artificial air ventilation.

Places and zones with sufficient artificial air ventilation are those with such ventilation capacity as to change air circulation ten times per hour. The outlet of the unloading air channels must be placed in a way that the evacuation of emerging vapors does not cause any form of danger.

Complete air circulation should be provided in case of artificial air ventilation.

Air ventilators or their motors should be explosion proof.

Make sure that the emergency exit is easily accessible.

The distillation unit must be positioned near one door that leads to an exit door.

Place a fire extinguisher near the unit (for fire type B and C).

Keep a distance of at least 8 (20cm) inches between the unit and any object to allow the recycler to cool off, and be able to perform the maintenance if necessary.

Place the unit on a flat surface away from heat, sparks and any source of flames.

Connect the unit to an efficient grounding pole.

INSTALLATION (cont'd)

The power cable is located on the right side of the unit. Connect to a 208-240 volt single phase, 15 amps power connection, per the area classification.

When service or maintenance work is required, disconnect the power supply or turn the power off at the main switch.

DISTILLER ELECTRICAL CONNECTIONS

The distiller is equipped with a 3-meter (10-foot) electrical cable for its power supply.

Provide for the installation of an adequate electrical box (CSA or U-L approved).

For the current and voltage specifications, refer to the nameplate on the right side panel.

It is suggested to locate the above-mentioned electrical box, at a height of 5 to 6 feet from the floor.

N.B.: In case the electrical wires are connected in a location where there are risks of explosion, an adequate explosion proof box must be installed (for example: protective type Class 1, Div. 1, Group D, with increased safety).

Once the electrical connections are complete, plug the recycler into the box and the keyboard is "**ON**".

Each time the power is disconnected and reconnected, the BECCA electronic keyboard will self-test itself. During **5 seconds**, all 5 lights and all 5 digits of 7 segment lights will stay on. Then the keyboard will display its own programming version (example: r 2.1) for a few seconds and then the thermometer light will stay "**ON**" and the actual temperature of the thermic oil will be displayed.

The control board is "**READY**" for instructions.

KEYBOARD OPERATIONS

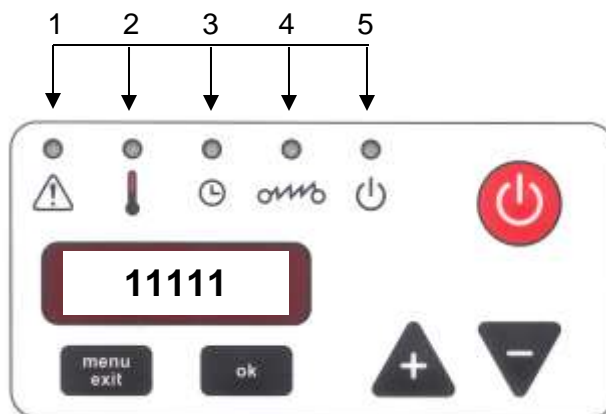

Keyboard Symbols:

1: Trouble 2: Temperature 3: Time 4: Electric Heater 5: Start/Stop

This BECCA temperature control board has been designed to control the different cycles during the distillation operation. It controls the temperature of the thermic oil, vapors and the distillate solvent coming out of the condenser. It uses this information to maintain a constant temperature, starts the cooling fan to cool the vapors coming off the condenser and stops the cycle if necessary.

Two heat sensors are used to read different temperatures. The thermic oil and the distillate solvent temperatures are captured using two thermocouples (because of high temperatures rising up to 392°F (200°C)). These sensors assure precision of the readings of the temperatures of $\pm 2^\circ\text{F}$ ($\pm 1^\circ\text{C}$).

The **BECCA** board also totals the number of hours of operation of the recycler. For every two thousand hours of operation, the display code "OIL" will appear to remind you that it is time to replace the thermic oil. The code "OIL" will remain displayed for ten (10) hours and then will disappear.

The display board consists of 5 digits of 7 segments, of 5 independent LEDs and of 5 touch-tone keys (7, 8, 9, 10 and 11) to operate the distiller. The operator can program the temperature, select the amount of time for the cycle, start or stop the cycle, choose Celsius or Fahrenheit degrees, and if necessary, display every code to verify the operation of the distiller in case of problems.

The safety devices will stop the cycle in case one of the sensors detects any trouble. The **TROUBLE** light will be displayed. The distiller **CANNOT** be re-started until the problem has been resolved.

There are two **TROUBLE** codes that can be displayed if a problem occurs:

- **O HI** code indicates that the **OIL** temperature is too **HIGH**.
- **L HI** code indicates that the recycled **SOLVENT** temperature is too **HIGH**.







The **TROUBLE** code can be erased by touching the + key (10) for each code. Once all the codes have been erased, the display returns to normal and the **TROUBLE** light disappears.

SELECTION BETWEEN FAHRENHEIT AND CELSIUS MODE

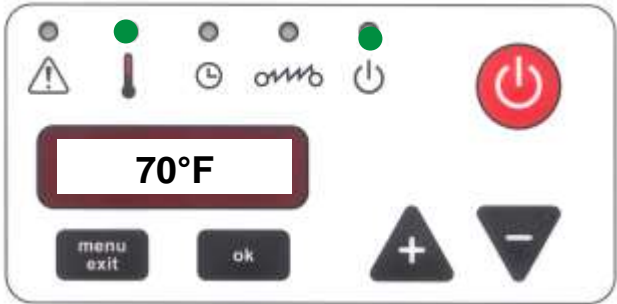

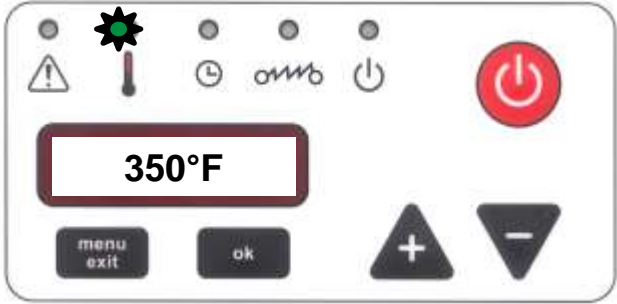

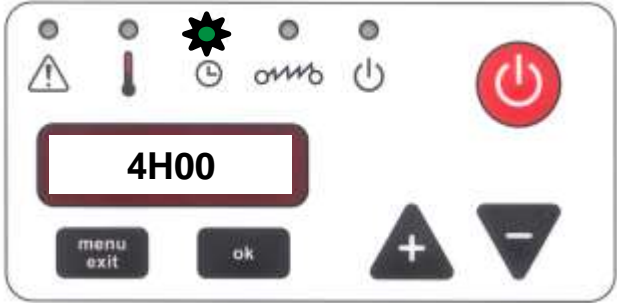

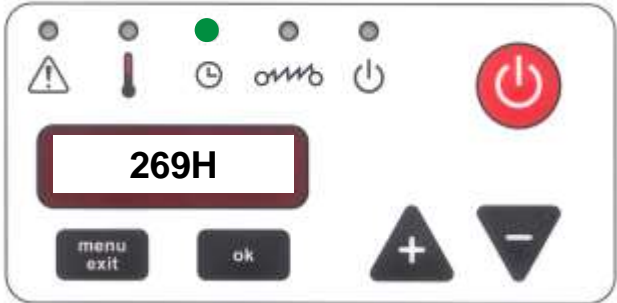

All units manufactured by **BECCA** are programmed in **FAHRENHEIT**.

To convert from Fahrenheit to Celcius, please follow the 11 steps indicated below:

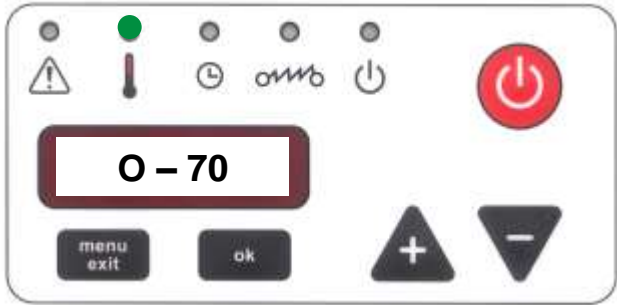

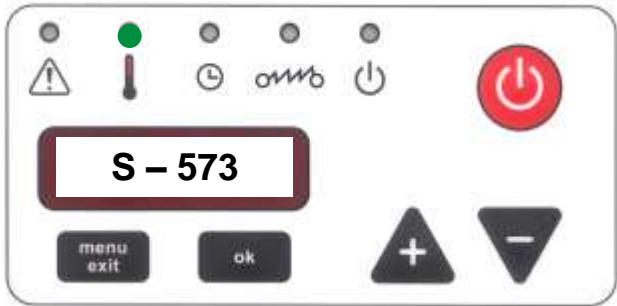

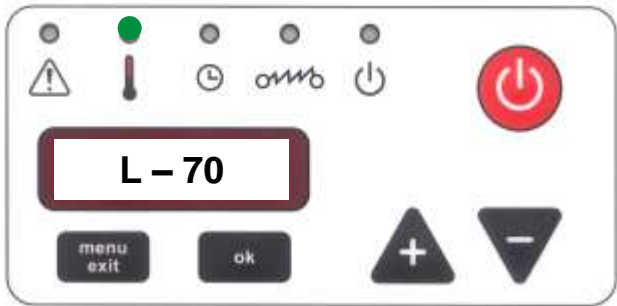

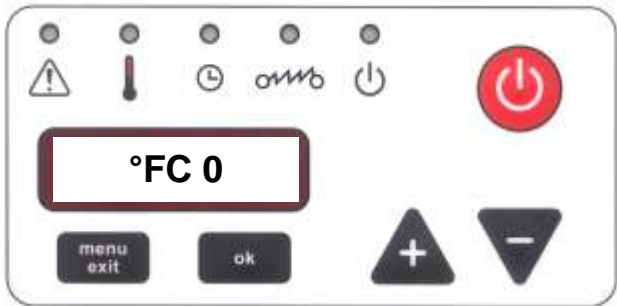
Proceed as follows:

PRESS	INDICATION	RESULT OF THE KEYBOARD
	<p>Thermometer light is on.</p> <p>Keyboard will display the actual temperature of the thermic oil.</p>	 <p>The control panel shows a thermometer icon with a green light above it. The display shows 70°F. Other icons include a warning triangle, a clock, a waveform, a power button, and a red power button. Below the display are 'menu exit' and 'ok' buttons, and '+' and '-' arrow buttons.</p>
	<p>Step 1 – Press MENU EXIT</p> <p>Thermometer light flashes.</p> <p>The selected temperature of the previous cycle is displayed.</p>	 <p>The control panel shows the thermometer icon with a green starburst above it, indicating it is flashing. The display shows 350°F. Other icons and buttons are the same as in the previous step.</p>
	<p>Step 2 – Press OK</p> <p>Clock light flashes.</p> <p>The amount of time selected during the previous cycle will be displayed.</p>	 <p>The control panel shows the clock icon with a green starburst above it, indicating it is flashing. The display shows 4H00. Other icons and buttons are the same as in the previous step.</p>
	<p>Step 3 – Press OK</p> <p>Clock light is on.</p> <p>The total amount of working hours of the recycler since day one will be displayed.</p>	 <p>The control panel shows the thermometer icon with a green light above it. The display shows 269H. Other icons and buttons are the same as in the previous step.</p>

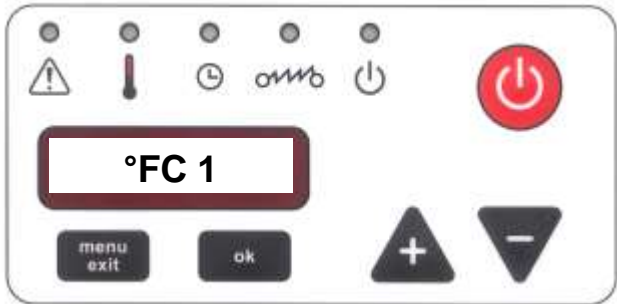
SELECTION BETWEEN CELSIUS AND FAHRENHEIT MODE (cont'd)

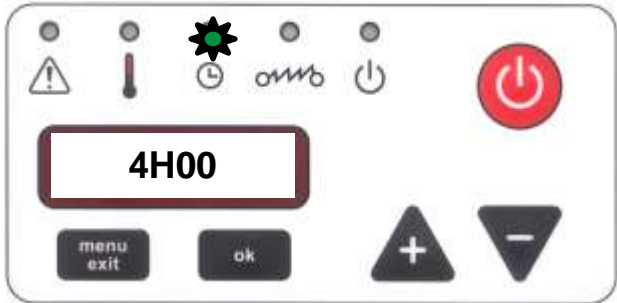
PRESS	INDICATION	RESULT OF THE KEYBOARD
	<p>Step 4 – Press </p> <p>Thermometer light is on.</p> <p>O = oil</p> <p>The actual temperature of the thermic oil will be displayed.</p>	
	<p>Step 5 – Press </p> <p>Thermometer light is on.</p> <p>S = steam</p> <p>Note: This feature has been disabled. The reading is invalid</p>	
	<p>Step 6 – Press </p> <p>Thermometer light is on.</p> <p>L = liquid</p> <p>The actual room temperature will be displayed.</p>	
	<p>Step 7 – Press START</p> <p>All lights are off.</p> <p>Display will indicate if set-up is in: 1 = Celsius or 0 = Fahrenheit</p>	

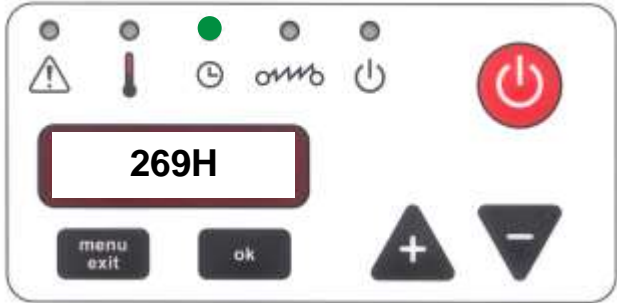
SELECTION BETWEEN CELSIUS AND FAHRENHEIT MODE (cont'd)

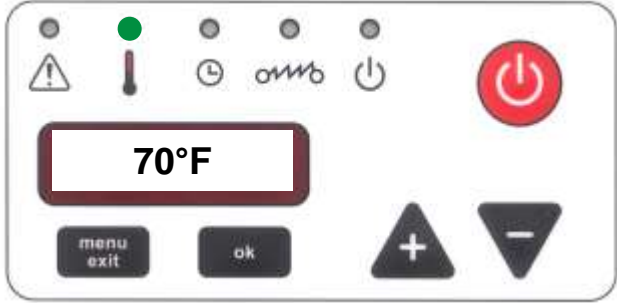
PRESS	INDICATION	RESULT OF THE KEYBOARD
	<p>Step 8 – Press + or –</p> <p>All lights are off.</p> <p>Press + or – to change mode: 1 = Celsius 0 = Fahrenheit</p>	
	<p>Step 9 – Press OK</p> <p>Clock light flashes.</p> <p>The amount of time selected during the previous cycle will be displayed.</p>	
	<p>Step 10 – Press OK</p> <p>Clock light is on.</p> <p>The total amount of working hours of the recycler since day one will be displayed.</p>	
	<p>Step 11 – Press MENU EXIT</p> <p>The temperature light is on.</p> <p>Your choice of mode is memorized and the keyboard will display the original menu of actual oil temperature in Celsius or Fahrenheit.</p>	

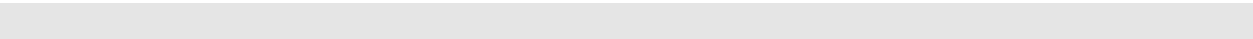

STARTING PROCEDURES

1. Preparation

NOTE: All **BECCA** recyclers are pre-tested and are shipped with thermic oil in it and are ready to be used.

- A. Install a clean container (of the same capacity or greater than the boiler) underneath the outlet tube where the recycled solvents come out.
- B. The clean container must have an air vent to allow normal fill-up.
- C. If you are using a metallic container, **it must be connected to a ground clip** supplied with the unit.

2. Plastic bag installation steps

- A. Pull the bottom corner of the bag inwards (3).
- B. Insert the retaining ring (#2)
- C. Fold access bag material inwards and fold neatly over the ring – make sure bag material covers the gap between ring grips
- D. Install Foaming Ring (#1) (optional)

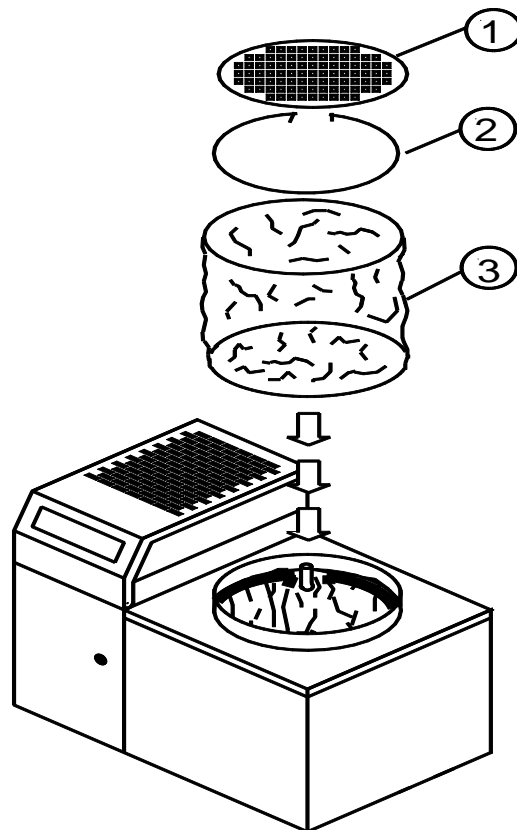

STARTING PROCEDURES (cont'd)

3. Filling up the Recycler

- A. Open the cover and fill the boiler with dirty solvents up to approximately $\frac{1}{2}$ - 1 inch (10 – 20 mm) below the grooved slot mark indicating the maximum level. You can also use the automatic loading option to fill up the recycler. The recycler can also be connected to any of the BECCA Spray Gun Washers.

Make sure any paint solids added to the boiler **do not exceed**:

- 3 Gal – 72 ounces of paint solids
- 6 Gal – 144 ounces of paint solids

- B. Before closing the cover, verify the condition of the lid gasket.
- C. According to the type of solvent to be distilled, you must use the proper cover gasket.

Part # 804008 (3 Gal.) Gasket in Orange Color for general use and for solvent mixtures

Part # 804018 (6 Gal.) Gasket in Orange Color for general use and for solvent mixtures

Using a non-suitable gasket will cause vapors to leak from the cover.

Anti – Foaming

Some solvents, during the boiling phase, create a quantity of foam that a correct separation of the solvent from the polluting product is not possible; in fact, in these cases, the distillate will still be dirty. To avoid this inconvenience, it is necessary to use the anti-foam kit (optional on request, Part #824021 for Model 9711 and Part #824022 for Model 9725).

Pay the utmost attention while the residues are drying. Some polluting products with an increase of temperature tend to carbonize with a considerable discharge of smoke from the distiller.

In case this occurs, press the (START / STOP) button to end the cycle.

In this case it is not possible to dry the residues at atmospheric pressure; proceeding to the vacuum distillation phase may solve the problem. This technique allows you to operate at a much lower temperature.

Opening the cover before the distillation cycle is complete will cause the gasket to swell. You must wait at least **one hour**.







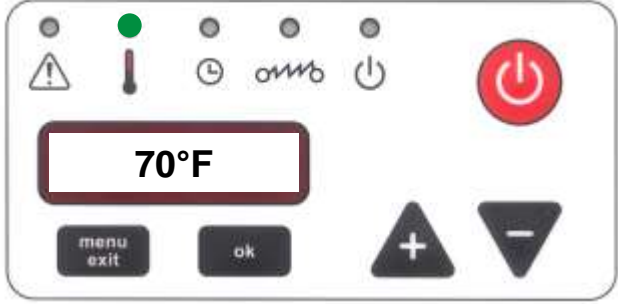

- D. Close and secure the cover properly. Your cover acts as a safety valve. **NEVER** modify the cover mechanism and **NEVER** use any tools to tighten the cover.
- E. **DO NOT SHAKE OR TILT** the loaded recycler during operation.

SELECTING THE TEMPERATURE AND DURATION OF THE CYCLE

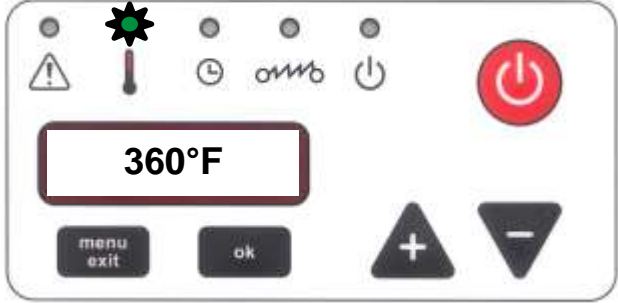

Before starting the cycle, you must select between **CELSIUS** and **FAHRENHEIT** temperatures. Temperature settings are determined by the **BOILING POINT** of the solvent to be reclaimed. The boiling points shown are for **NEW SOLVENTS**.

To recycle contaminated solvents, the temperature setting **MUST BE** Approximately 80°F (30°C) **HIGHER** than the boiling point.

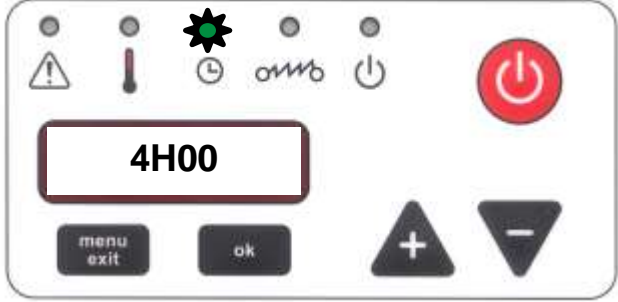
NOTE: The temperature setting starting point indications will vary according to the solvent used and the percentage of contaminants in the solvent.

PRESS	INDICATION	RESULT OF THE KEYBOARD
	<p>Thermometer light is on.</p> <p>Keyboard will display the actual temperature of the thermic oil.</p>	 <p>The control panel displays a thermometer icon with a green light above it. The central display shows '70°F'. Below the display are 'menu exit' and 'ok' buttons, and to the right are '+' and '-' arrow buttons. A red power button is in the top right corner.</p>
	<p>Thermometer light flashes.</p> <p>You have the option to select the temperature for the cycle by pressing keys.</p> <p style="text-align: center;">  OR  </p>	 <p>The control panel displays a thermometer icon with a flashing green star above it. The central display shows '360°F'. Below the display are 'menu exit' and 'ok' buttons, and to the right are '+' and '-' arrow buttons. A red power button is in the top right corner.</p>
	<p>You have the option to select your own amount of time for the cycle by pressing keys:</p> <p style="text-align: center;">  OR  </p> <p>Recycler will automatically stop when time has expired.</p>	 <p>The control panel displays a clock icon with a flashing green star above it. The central display shows '4H00'. Below the display are 'menu exit' and 'ok' buttons, and to the right are '+' and '-' arrow buttons. A red power button is in the top right corner.</p>

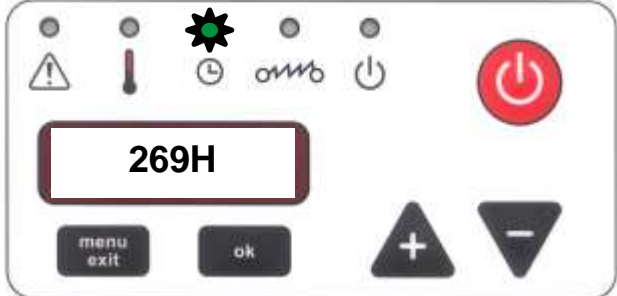
SELECTING THE TEMPERATURE AND DURATION OF THE CYCLE (cont'd)

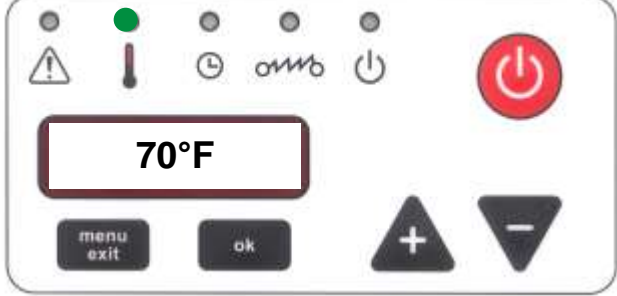
PRESS	INDICATION	RESULT OF THE KEYBOARD
	<p>Clock light is on.</p> <p>The total amount of working hours of the recycler since day one will be displayed.</p> <p>This cannot be changed.</p> <p>For every 2,000 hours of operation the message OIL will flash to notify you to change the thermic oil.</p>	
	<p>Thermometer light is on.</p> <p>Keyboard will display the actual temperature of the thermic oil.</p>	

STARTING THE UNIT

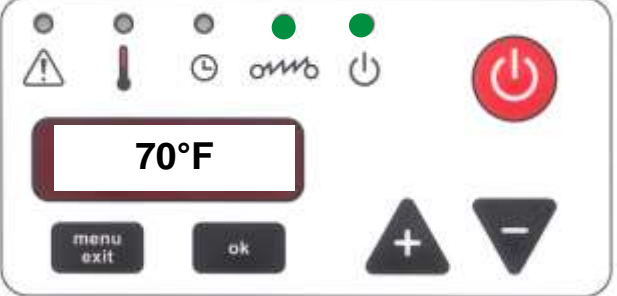
PRESS	INDICATION	RESULT OF THE KEYBOARD
	<p>Press the START/STOP key.</p> <p>ON light will go on.</p> <p>Electric element will start heating the thermic oil.</p> <p>Element light will go on.</p> <p>The Lights will Flash:</p> <ul style="list-style-type: none"> • Temperature for 3 sec • Time Setting for 3 sec • Elapsed Time for 3 sec 	

DURING THE DISTILLATION CYCLE

- A. Every **5 seconds**, the keyboard will display 3 different readings:
1. Selected boiling temperature: (Thermometer light will **flash**).
 2. Amount of time selected for that cycle: (Clock light will **flash**).
 3. Elapsed time since starting the unit: (Clock light will be **on**).
- B. Cooling fan will start turning.
- C. Recycled solvents will start dripping approximately **one hour** after the start-up.
- D. At the end of the cycle, the **ON** light will **flash** for about **10 minutes**. The heating element will shut off but the cooling fan will remain on during the cooling cycle.
- E. The cooling fan will automatically shut off at the end of the cooling cycle.

AT THE END OF THE CYCLE

The keyboard will display the total elapsed time for that cycle.

All lights will shut off except the **ON** light.

You can now remove the residues.

Press the stop key.

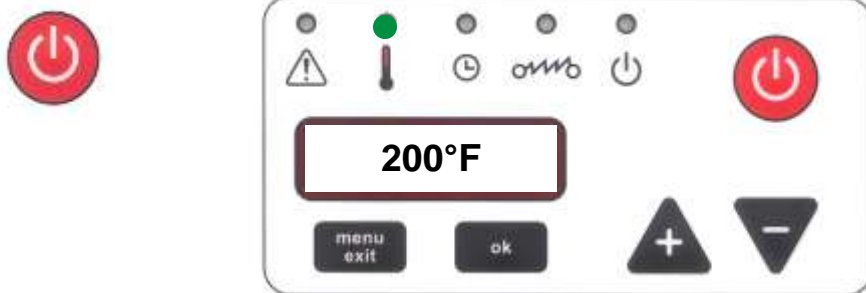

This will show the Temperature of the unit

WARNING! Do Not Open the Cover until the Temperature is below at least 200°F. Ideal Temperature is 170°F

Once below the 200°F, you can remove the Cover and residues

CONTROL MODULE SELF-TESTING PROCEDURES

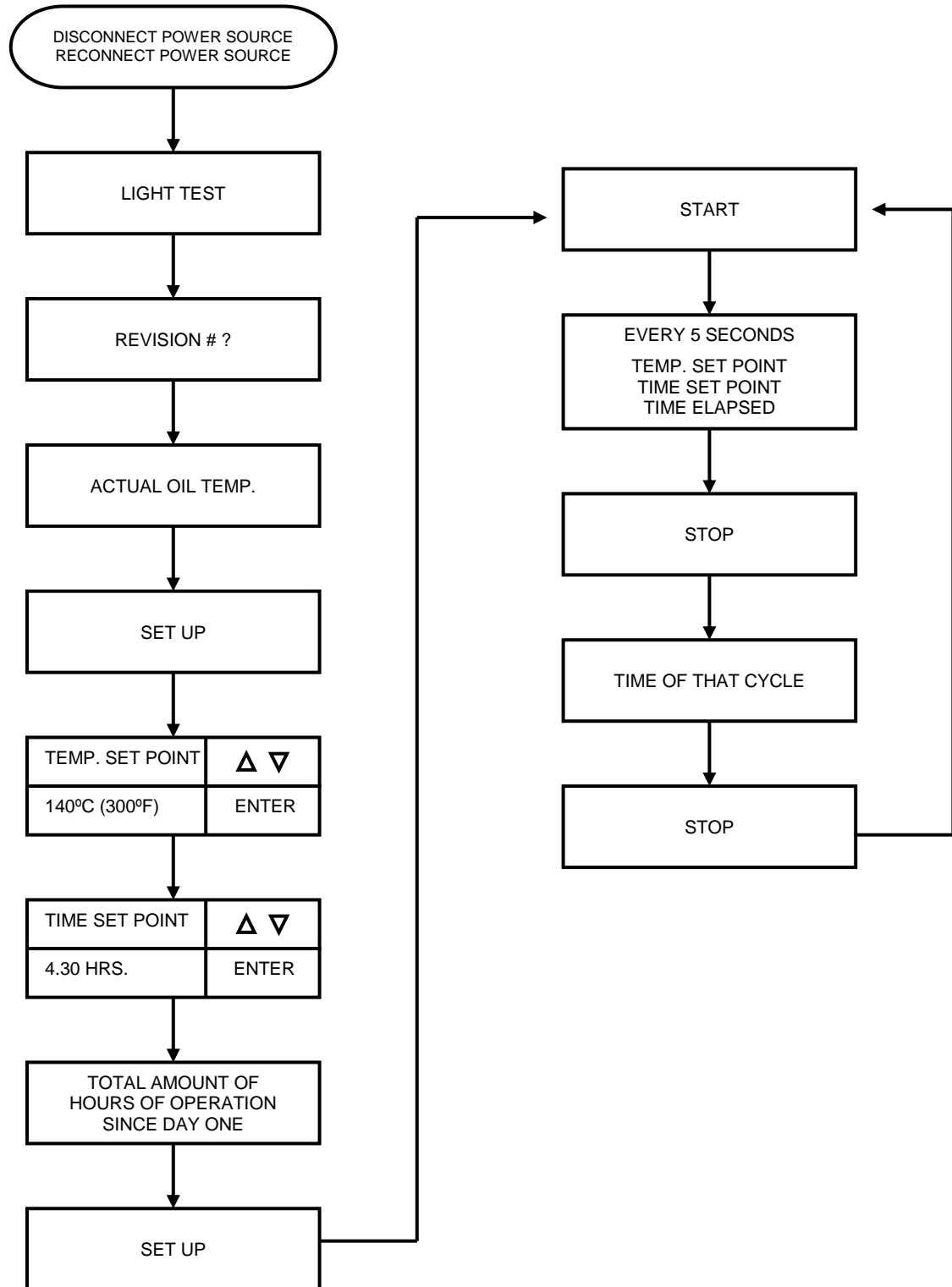

FLAMMABLE SOLVENTS

SOLVENT TYPE	Distillation Temperature		Temp. Class	Ignition Temperature		Gasket	Condenser	
	°C	°F		°C	°F		Becca "S"	Copper
Acetone	56	133	T2	465	869	A	A	A
Amyl Alcohol	137	279		300	572	A		B
Amyl Acetate	126-155	259-311	T2	375	707	A	A	A
B Naphtha- Heavy	150-220*	302-428*	T-3	250	482	A	A	A
Benzol (Benzene)	80	176	T-1	560	1040	A	B	B
Butanol (Butyl Alcohol)	82	180		477	892	A	A	A
Butyl Acetate	128	262	T-2	370	698	A	B	A
Butyl Carbinol	234*	453*	T-3	228	442	A		A
Butyl Cellosolve	173*	343*	T-3	239	462	A		A
Butyl Cellosolve Acetate	192*	378*	T-3	280	536	A		A
Butyl Diglycol	234*	453*	T-3	228	442	A	A	A
Butyl Glycol	173*	343*	T-3	239	462	A	A	A
Cabinol	65	149	T-2	385	725		B	B
Cellosolve	143	289	T-3	235	455		B	B
Cellosolve Acetate	156	313	T-2	377	711		B	B
Cyclohexane	81	178	T-3	260	500	A	B	B
Cyclohexanol	162	324	T-3	300	572	A	B	B
Cyclohexanone	155	311	T-2	419	786	A	B	B
Dimethylformamide (DMF)	153	307	T-2	445	833	A	A	A
Ethyl Acetate	79	174	T-2	427	801	A	A	A
Ethyl Alcohol (Ethanol)	78	172				A	A	A
Ethyl Benzene	136	277	T-1	466	871	A	A	A
Ethyl Glycol Acetate	156	313	T-2	377	711	A	A	A
Hexamethylene	81	178	T-3	260	500		B	A
Iso Amyl Acetate	125-155	257-311	T-2	375	707	A		A
Iso Butyl Acetate	104-119	219-246	T-2	420	788	A		
Iso Butyl Alcohol	111	232	T-2	430	806	A		
Iso Propane	83	181	T-2	400	752		B	B
Iso Propyl Acetate	89	192	T-2	460	860	A	A	B
Iso Propyl Alcohol	83	181	T-2	400	752	A		A
Iso Propyl Glycol	143	289	T-2	345	653	A		
Lacquer Solvents	140	284	T2	535	995	A	A	A
Methyl Acetate	58	136	T-2	475	887	A	B	A
Methyl Cellosolve	124	255	T-3	285	545	A	B	B
Methyl Cellosolve Acetate	156	313	T-2	377	711	A	B	B
Methyl Ethyl Ketone (M.E.K.)	80	176	T-1	530	986	A	A	A
Methyl Glycol Acetate	137-152	278-305	T-2	380	716	A	A	A
Methyl Isobutyl Ketone (M.I.B.K.)	117	243	T-1	459	858	A	B	B

FLAMMABLE SOLVENTS (cont'd)

SOLVENT TYPE	Distillation Temperature		Temp. Class	Ignition Temperature		Gasket	Condenser	
	°C	°F		°C	°F		Becca "S"	Copper
N. Butanol	118	244	T2	366	691			
N. Hexanol	70	158	T3	240	464			
N. Octanol	126	259	T3	220	428	A		
N. Pentanol	138	280	T2	327	621	A		
N. Propanol	98	208	T2	371	700			
N. Propyl Alcohol	98	208	T2	371	700	A	A	A
Naphtha-Light	155-200*	132-392*	T-3	230	436	A	A	A
Paint Thinner	140	284	T2	535	995	A	B	B
Sec. Butyl Alcohol	101	214	T2	390	734			
Toluol (Toluene)	112	232	T1	535	995	A	A	A
Turpentine	152	170	T3	250	482	A	A	A
White Spirit	150-190*	302-374*	T3	254	489		A	A
Xylol (Xylene)	140	284	T1	525	977	A	A	B

NON-FLAMMABLE CHLORINATED SOLVENTS

SOLVENT TYPE	Distillation Temperature		Temp. Class	Ignition Temperature		Gasket	Condenser	
	°C	°F		°C	°F		Becca "S"	Copper
1,1,1, Trichloroethane-3xl	74*	165*		537	998	A		
1,1,2,2, Tetrachloroethane	147*	297*		NF	NF	A	C	B
1.2, Dichloropropane	95*	203*		557	1035	A		
Chloroform	61*	142*		NF	NF	A	A	A
Chlorotene-Baltane	74*	165*				A		
Dichloroethane	84*	183*		413	775	A		
Freon 113	46*	115*				A	A	A
Methylchloroform	74*	165*		537	998	A		
Methylene Chloride Dichloromethane	40*	104*		NF	NF	A	A	A
Perchloroethylene	121*	250*		NF	NF	A	A	A
Carbon Tetrachloride	77*	172*		NF	NF	A		
Tetrachloroethylene	121*	250*		NF	NF	A		
Trichloroethylene-tri-	87*	187*		410	770	A		
Vorclin – Althene-87	188*	370*				A	B	B

WARNING

The information and data set forth in this catalog or the information disclosed by a representative is for your general information only. Many factors influence the resistance of materials to corrosion, such as temperature, concentration, aeration and contaminants.

A – Excellent

B – Good

C – Poor

NF – Non-Flammable

* – Vacuum distillation only

Blank – Information not available

THERMIC OIL CHANGING PROCEDURES

Recommended Annually or 1500 hours, which ever comes first

1. Remove the oil plug (32) and the overflow valve (33).
2. Place the empty oil collector container below the plug (32b) and remove the plug.
3. When empty, remove the container and re-install the plug (32b).
4. Place a funnel on overflow port (33) and  pour new thermic oil (**Part # 630066 – 1 Gal**) until full. **See Name Plate for required Oil Capacity**
5. Re-install the oil plug (32) and the overflow valve (33).

Thermic oil reservoir capacity Prior to October 2005	2 Gallons	7 Liters	3 Gallons	11 Liters
Thermic oil reservoir capacity After Oct 2005 to Present	2.25 Gallons	8.5 Liters	3.25 Gallons	12.3 Liters

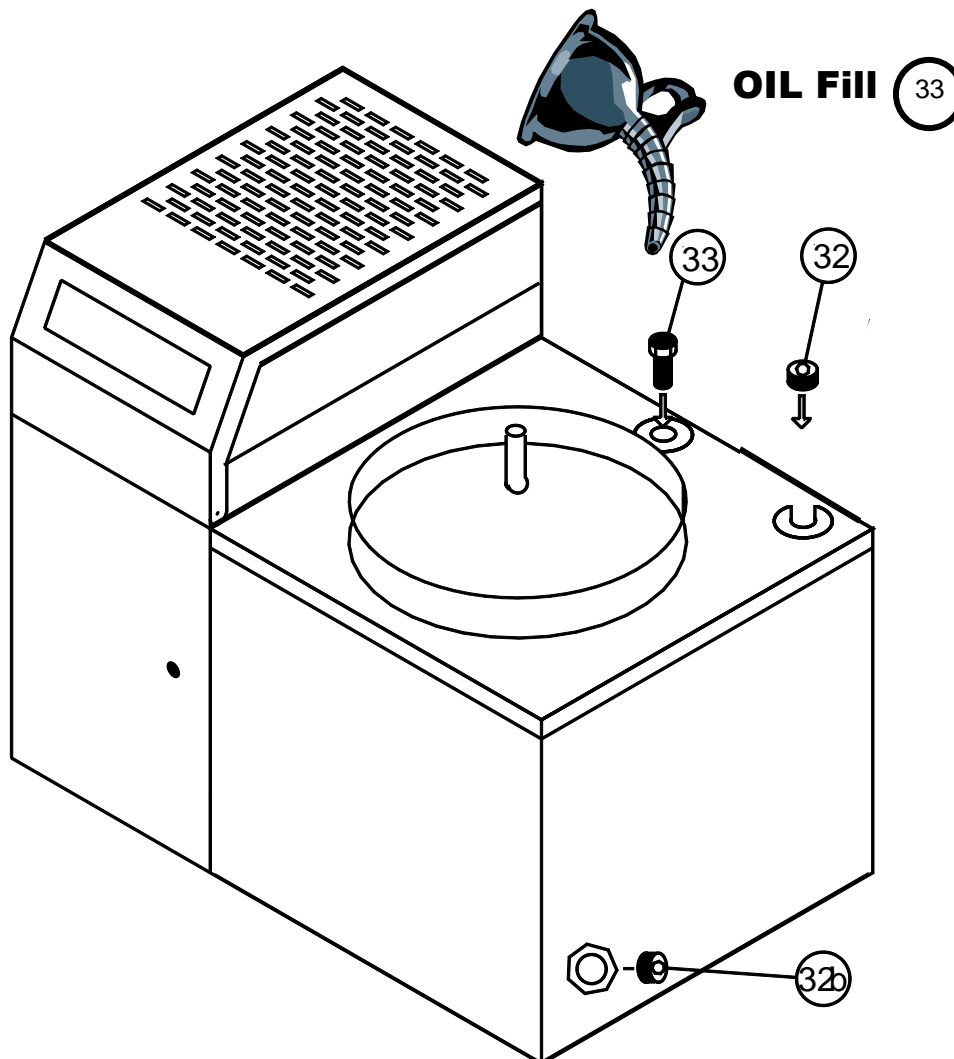

TROUBLESHOOTING GUIDE

Distillation at Atmospheric Pressure

PROBLEM	CAUSE	SOLUTION
Unit heats but does not distill.	<ul style="list-style-type: none"> - More paint in unit than it can handle causing a heat absorber - Tank bottom is dirty. - Thermic oil is worn out. - Lack of thermic oil. - Solvent boiling temperature is higher than the temperature set on the control panel. - Solvent boiling temperature is higher than distiller's maximum working temperature. 	<ul style="list-style-type: none"> - No more paint than allowed: 3 Gal - 72 ounces of paint solids 6 Gal – 144 ounces of paint solids - Clean the tank - Change thermic oil - Add thermic oil - Set a higher temperature on the control panel. - Use a solvent with a lower boiling temperature or use vacuum assist kit (optional).
Vapor comes out from the cover.	<ul style="list-style-type: none"> - Polluting products overheating. - Polluting products decomposing. - Dirt on cover gasket. 	<ul style="list-style-type: none"> - Reduce time and/or working temperature. - Use vacuum distill with the suitable kit. - Clean cover gasket.
Cover gasket swells.	<ul style="list-style-type: none"> - Cover is opened while distiller is hot. 	<ul style="list-style-type: none"> - Open the cover at least one hour after the cycle is complete.
Solvent leaks from the gasket.	<ul style="list-style-type: none"> - Worn out gasket. - Vapor manifold is clogged. - Vapor condenser is clogged. 	<ul style="list-style-type: none"> - Replace the gasket. - Using a funnel, pour in clean solvent, wash vapor tube and blow air into the tube. - Blow out condenser w/ compressed air or replace the condenser.
Unit is in operation mode but does not heat. Indicator light is ON .	<ul style="list-style-type: none"> - Temperature is set at zero. - Burnt out heater. - One of the thermostats is defective. 	<ul style="list-style-type: none"> - Set a higher temperature on the control panel - Replace heater - Change the faulty thermostat.
Distills only part of the dirty solvent.	<ul style="list-style-type: none"> - Insufficient operating time selected. - The undistilled solvent has a boiling temperature higher than the temperature set on the control panel. - Solvent-boiling temperature is higher than the distiller's maximum working temperature. - Large amount of sludge in the bottom of the unit acting as insulator 	<ul style="list-style-type: none"> - Increase the operating time. - Set a higher temperature on the control panel. - Convert to a lower boiling solvent or use a vacuum operated unit. - Place less solid material in tank.

TROUBLESHOOTING GUIDE (cont'd)

Distillation at Atmospheric Pressure

PROBLEM	CAUSE	SOLUTION
Trouble light flashes . Display shows " LHI "	Condensed solvent temperature is over 60°C (140°F). <ul style="list-style-type: none"> - Failed Temp Sensor - Fan motor burns out. - Vapor condenser internally dirty - Vapor condenser externally scaled. 	<ul style="list-style-type: none"> - Replace Temp Sensor - Replace the fan motor. - Clean by compressed air jet. - Wash it, by pouring clean solvent with a funnel into manifold.
Trouble light flashes . Display shows " OHI "	<ul style="list-style-type: none"> - Thermic oil is worn out. - Lack of thermic oil. 	<ul style="list-style-type: none"> - Change thermic oil - Add thermic oil
Unit Shuts off Automatically and then strats up Automatically	<ul style="list-style-type: none"> - Power Supply Board has Triac Switch Failure. 	<ul style="list-style-type: none"> - Replace Power Supply Board
Distillate comes out dirty.	<ul style="list-style-type: none"> - Filled to high in the tank, causing overflow. - Solvent foams. - Temperature set on control panel too high. - Vapor manifold or condenser dirty. 	<ul style="list-style-type: none"> - Load ½" – 1" below ring. - Wait at least 48 hours after utilizing the solvent before starting the next distillation. Use BECCA Foam Grill (Optional) - Reduce working temperature. - Wash it by pouring clean solvent with a funnel into manifold.
Distillate assumes a greenish color. Condenser is becoming corroded.	<ul style="list-style-type: none"> - The solvent is acidic. - Distilling a chlorinated solvent. - Temperature set on the control panel is higher than the temperature indicated on page 26 or 27. - Solvent acidifies. 	<ul style="list-style-type: none"> - Replace copper condenser with a stainless steel condenser. - Set the correct working temperature. - Replace the solvent immediately.
Solvent under the Recycler Bag	<ul style="list-style-type: none"> - This occurs when the solvent condenses inside the unit on its sides and drips through the gap between ring grips. 	<ul style="list-style-type: none"> - assure that the Recycler Bag is folded neatly and pressed up against the tank wall to reduce amount. <p>Note: Some solvent at the bottom of the boiler is good to prevent sticking of the Bag</p>
Distillation time is more than 4 ½ hours .	<ul style="list-style-type: none"> - There is a considerable percentage of water in the dirty solvent. - Lack of thermic oil. - Thermic oil is worn out. - Heater is scaled. 	<ul style="list-style-type: none"> - Replace the solvent. - Add thermic oil. - Change thermic oil. - Remove thermic oil and clean the heater.

MAINTENANCE SCHEDULE

Each use

- Replace Recycler Bag 630003 (3 Gal)
660006 (6 Gal)
- Remove any contaminants from the bottom of the Boiler

Each day

- Wipe-down the unit with solvent. The paint and decals are solvent resistant.
- Remove any contaminants from the bottom of the Boiler

Semi-Annually

- Blow off condenser (externally) to remove dust and dirt
- Replace Becca Protect™ Maintenance Coating (831004)
- Review Ground Clamp (823079)

Annually

- Replace Seal 804008 (3 Gal)
804018 (6 Gal)
- Blow out condenser (internally)
- Change Oil (630066) or 1500 Hours (which ever is first)
- Review & Replace illegible or damaged Decals
- Complete Electrical Diagnostic

SCHEMATIC OF UNIT

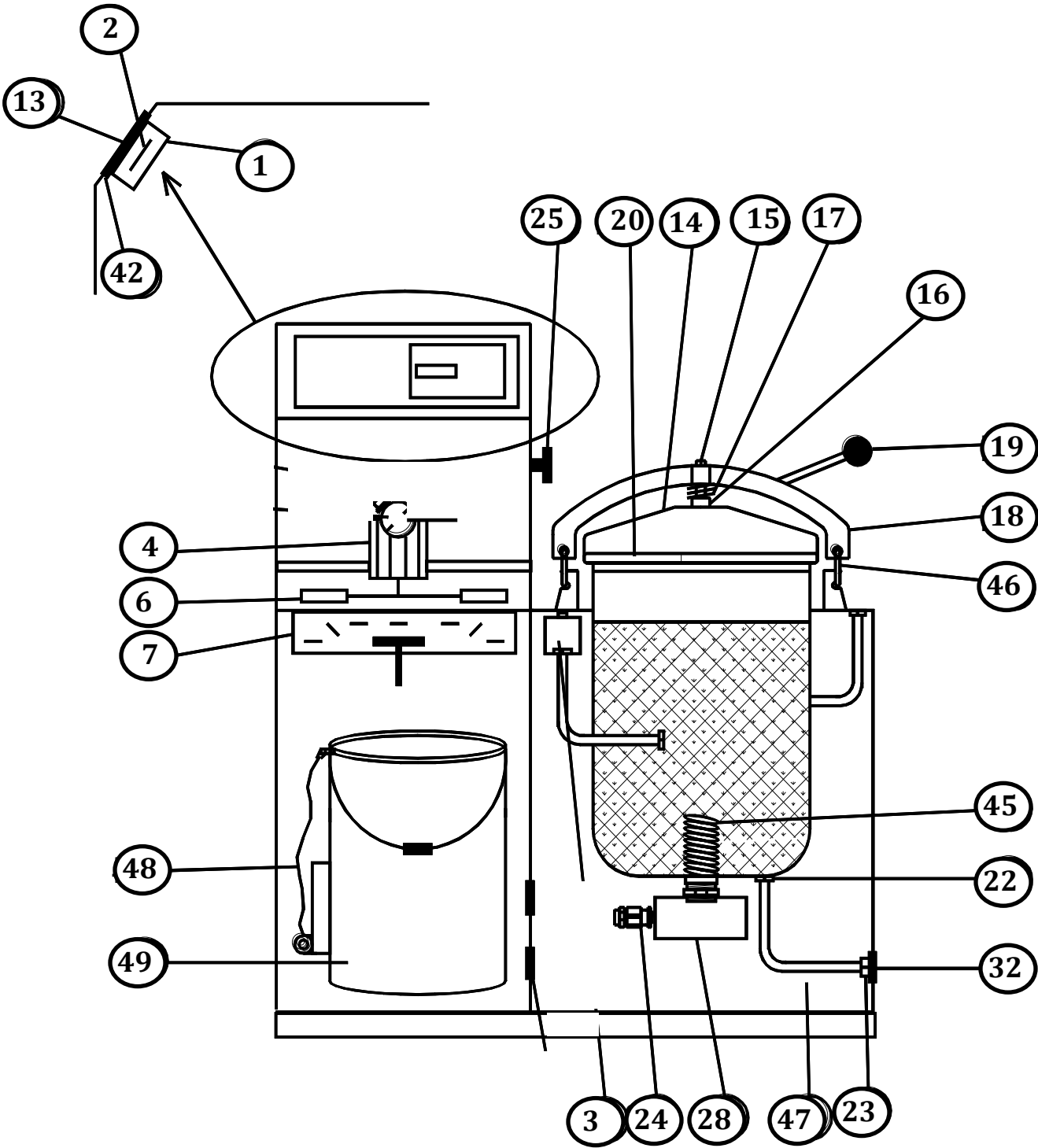

SCHEMATIC OF UNIT (cont'd)

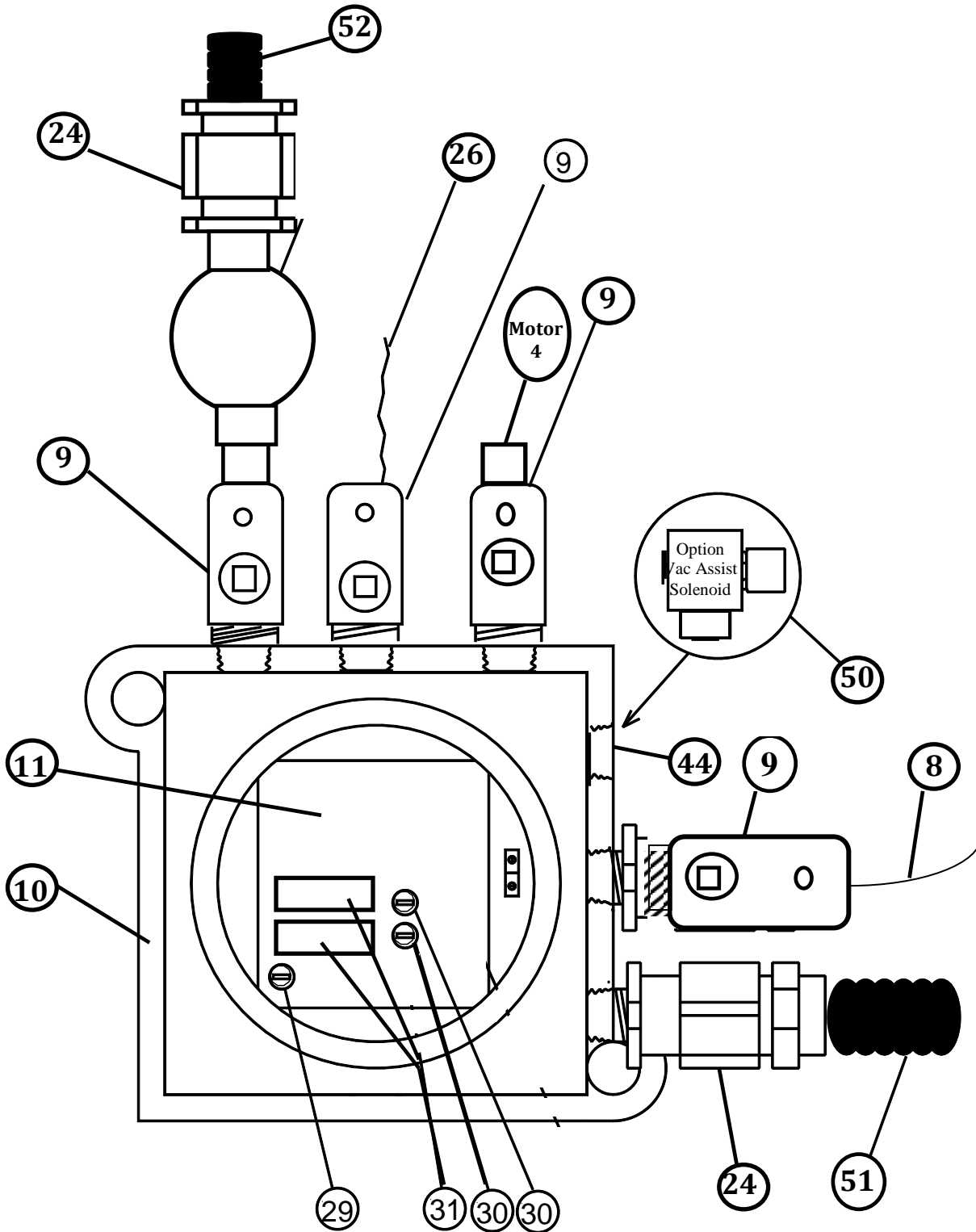

SCHEMATIC OF UNIT (cont'd)

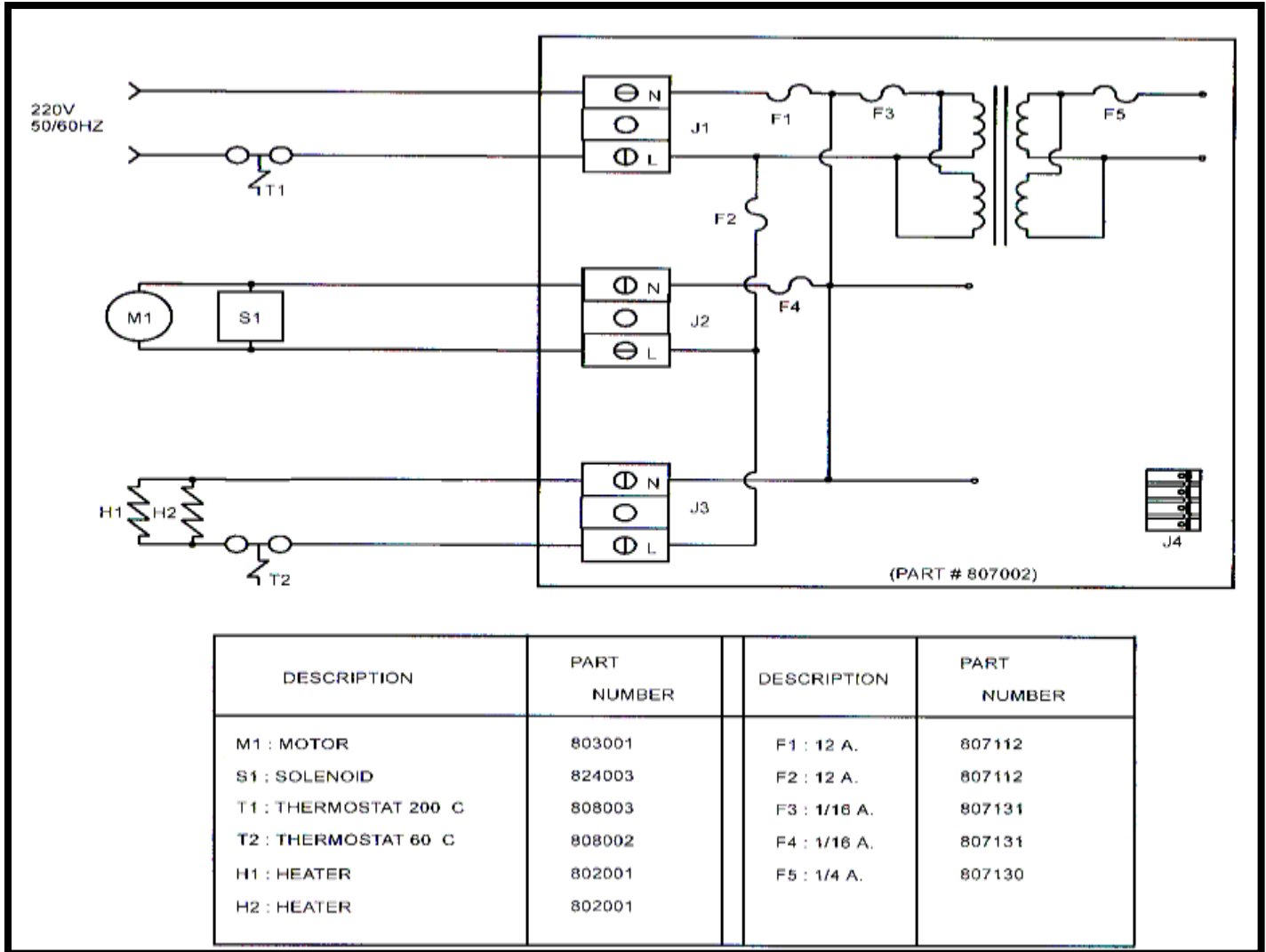

F1 = Power

F2 = Power

F3 = Transformer

F4 = Transformer

F5 = Transformer Secondary

SCHEMATIC OF UNIT (cont'd)

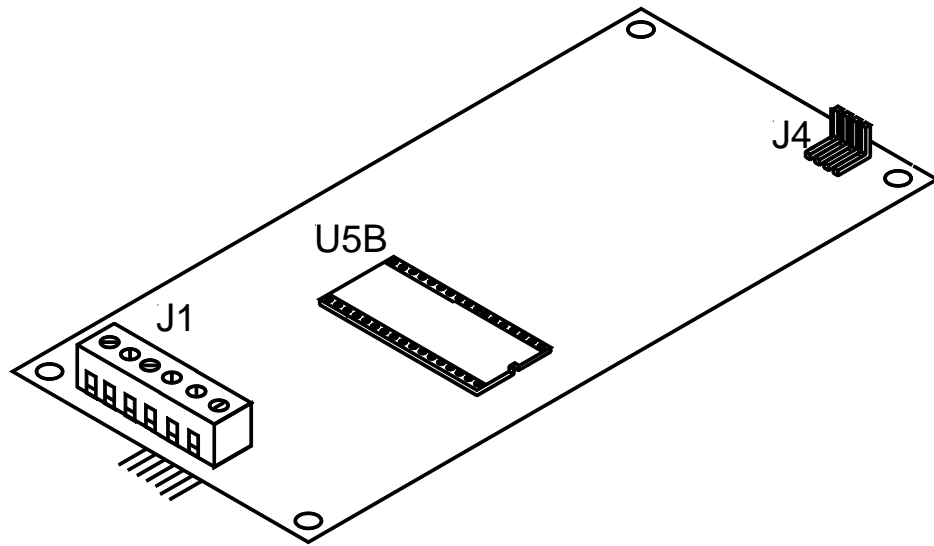
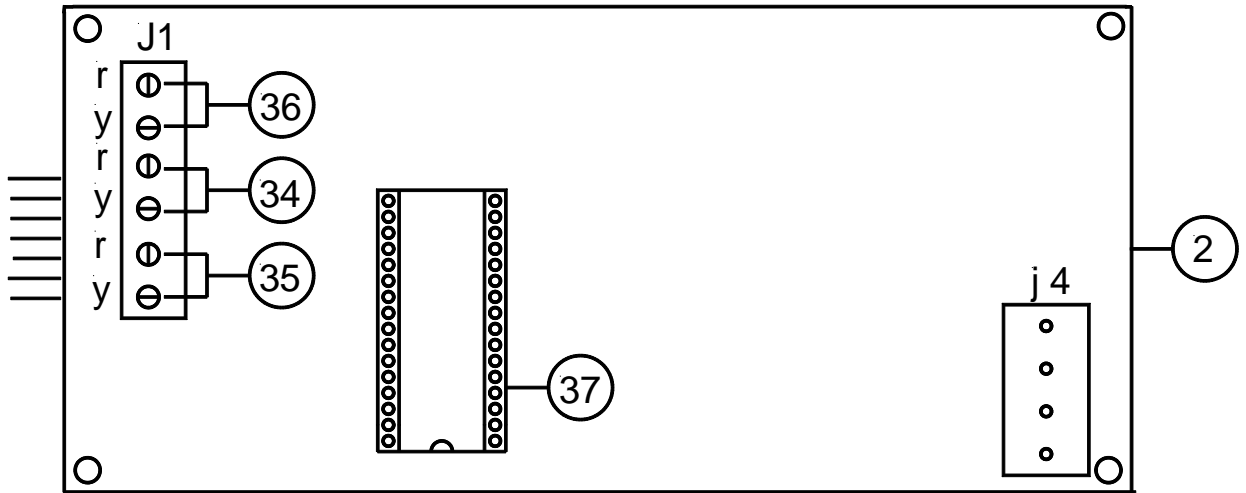

SCHEMATIC OF UNIT (cont'd)

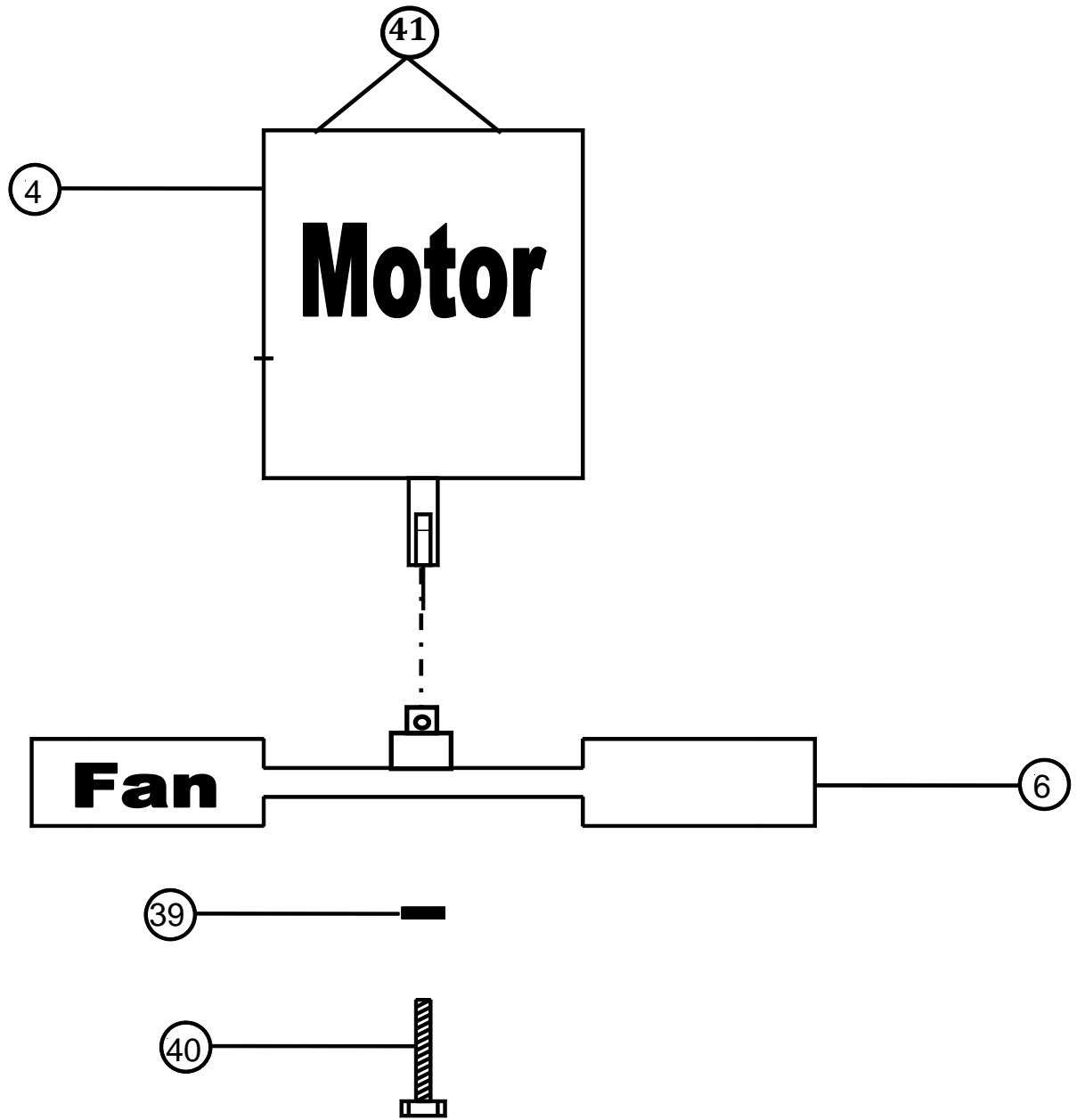

SPARE PARTS NUMBERS FOR RECYCLER

INDEX	PART #	DESCRIPTION	QUANTITY
1	823075	CONTROL BOARD PROTECTIVE BOX	1
2	807001K	ELECTRONIC CONTROL BOARD	1
3	820004	OVERFLOW THERMIC OIL TANK	1
4	803001	EXPLOSION-PROOF MOTOR (220 volts – 60 Hz)	1
	803004	EXPLOSION PROOF MOTOR (220 volts – 50 Hz)	Optional
6	803003	COOLING FAN	1
7	805002	COPPER CONDENSER	1
	805003	STAINLESS STEEL CONDENSER	Optional
8	807126	JACK PLUG CABLE	1
9	822012	EXPLOSION-PROOF CONNECTOR (Model F)	1
10	822001	EXPLOSION-PROOF JUNCTION BOX FOR POWER SUPPLY	1
11	807002K	POWER SUPPLY BOARD	1
12	830101	FRAME	1
13	807003	KEYBOARD	1
14	801010	STAINLESS STEEL COVER (9711)	1
	801020	STAINLESS STEEL COVER (9725)	1
15	801002	CAP SCREW	1
16	801003	TENSION ADJUSTING NUT	1
17	801004	SPRING (small)	1
	801005	SPRING (medium)	1
	801006	SPRING (large)	1
18	801008	COVER ARCH (9711)	1
	801018	COVER ARCH (9725)	1
19	801007	HANDLE KNOB	1
20	804008	COVER GASKET (9711-orange)	1
	804018	COVER GASKET (9725-orange)	1
24	822004	EX-PROOF CONNECTOR	5
25	824552	USED SOLVENT TRANSFER VALVE	1
26	808003	OIL SAFETY WORKING THERMOSTAT – 0°-200°C (30°-392°F)	1
28	822002	EXPLOSION-PROOF HEATER JUNCTION BOX	1
29	807130	FUSE - 1/4 AMP.	1
30	807131	FUSES - 1/6 AMP.	2
31	807112	FUSES - 12 AMP.	2
32	823514	PLUG	3

SPARE PARTS NUMBERS FOR RECYCLER (cont'd)

INDEX	PART #	DESCRIPTION	QUANTITY
33	823008	OVERFLOW OIL VALVE	1
34	807122K	OIL THERMOCOUPLE SENSOR	1
36	807123K	LIQUID THERMOCOUPLE SENSOR	1
37	807025	CONTROL CHIP	1
38	803007	FAN SPACER (Older Models Prior to 2005)	1
39	803006	LOCK WASHER	1
40	803005	FAN MOTOR SCREW	1
42	823080	GASKET	1
43	823011	CLOSE NIPPLE – 1/2	1
44	823504	PLUG – 1/2	1
45	802002	HEATER	1
46	801009	SAFETY LATCH (9711)	2
	801019	SAFETY LATCH (9725)	2
47	820009	INOX FLEXIBLE CABLE 24”	1
48	823579	GROUND WIRE WITH CLIP	1
49	823200	5 GALS / 20 LITERS SOLVENT PAIL	(optional)
50	824003	SOLENOID (OPTIONAL VACUUM ASSIST)	1
51	821003	HEATER ELECTRIC CABLE 10’ Section	1
52	821003	POWER CABLE 10’ Section	1
		<u>OPTIONAL ACCESSORIES</u>	
	823200	5 GALS / 20 LITERS SOLVENT PAIL	
	630003 - 25	PLASTIC LINER BAG – 3 Gal (25 Bags)	
	630003 - 100	PLASTIC LINER BAG – 3 Gal (100 Bags)	
	630006 - 25	PLASTIC LINER BAG – 6 Gal (25 Bags)	
	660006 - 100	PLASTIC LINER BAG – 6 Gal (100 Bags)	
	831004	Becca Protect Film 30” x 200’ Roll – Peel away film	

INSTALLATION CODE REQUIREMENTS

GENERAL ARRANGEMENT	REVISIONS	DATE	BY	APP'D
BECCA				
BECCA 3403.1.1 BECCA 3403.1.2 BECCA 3403.1.3 BECCA 3403.1.4 BECCA 3403.1.5 BECCA 3403.1.6 BECCA 3403.1.7 BECCA 3403.1.8 BECCA 3403.1.9 BECCA 3403.1.10 BECCA 3403.1.11 BECCA 3403.1.12 BECCA 3403.1.13 BECCA 3403.1.14 BECCA 3403.1.15 BECCA 3403.1.16 BECCA 3403.1.17 BECCA 3403.1.18 BECCA 3403.1.19 BECCA 3403.1.20 BECCA 3403.1.21 BECCA 3403.1.22 BECCA 3403.1.23 BECCA 3403.1.24 BECCA 3403.1.25 BECCA 3403.1.26 BECCA 3403.1.27 BECCA 3403.1.28 BECCA 3403.1.29 BECCA 3403.1.30 BECCA 3403.1.31 BECCA 3403.1.32 BECCA 3403.1.33 BECCA 3403.1.34 BECCA 3403.1.35 BECCA 3403.1.36 BECCA 3403.1.37 BECCA 3403.1.38 BECCA 3403.1.39 BECCA 3403.1.40 BECCA 3403.1.41 BECCA 3403.1.42 BECCA 3403.1.43 BECCA 3403.1.44 BECCA 3403.1.45 BECCA 3403.1.46 BECCA 3403.1.47 BECCA 3403.1.48 BECCA 3403.1.49 BECCA 3403.1.50 BECCA 3403.1.51 BECCA 3403.1.52 BECCA 3403.1.53 BECCA 3403.1.54 BECCA 3403.1.55 BECCA 3403.1.56 BECCA 3403.1.57 BECCA 3403.1.58 BECCA 3403.1.59 BECCA 3403.1.60 BECCA 3403.1.61 BECCA 3403.1.62 BECCA 3403.1.63 BECCA 3403.1.64 BECCA 3403.1.65 BECCA 3403.1.66 BECCA 3403.1.67 BECCA 3403.1.68 BECCA 3403.1.69 BECCA 3403.1.70 BECCA 3403.1.71 BECCA 3403.1.72 BECCA 3403.1.73 BECCA 3403.1.74 BECCA 3403.1.75 BECCA 3403.1.76 BECCA 3403.1.77 BECCA 3403.1.78 BECCA 3403.1.79 BECCA 3403.1.80 BECCA 3403.1.81 BECCA 3403.1.82 BECCA 3403.1.83 BECCA 3403.1.84 BECCA 3403.1.85 BECCA 3403.1.86 BECCA 3403.1.87 BECCA 3403.1.88 BECCA 3403.1.89 BECCA 3403.1.90 BECCA 3403.1.91 BECCA 3403.1.92 BECCA 3403.1.93 BECCA 3403.1.94 BECCA 3403.1.95 BECCA 3403.1.96 BECCA 3403.1.97 BECCA 3403.1.98 BECCA 3403.1.99 BECCA 3403.1.100				

<p>Intermediate Mix Room</p>	<p>Three-Sided Mix Room</p>	<p>Free Standing Mix Room</p>
<p>Entire System Outside Mix Room</p>	<p>Entire System Inside Mix Room</p>	

Classification Zones are per:

- A) NFPA 33 Standard for Spray Application Using Flammable and Combustible Materials, Section 4.3.5
- B) International Fire Code, Chapter 34 Flammable and Combustible Liquids 3403.1.1

Zone requirements apply to both Gun Cleaners and Recyclers together and stand alone

SP[®] US

© BECCA 2019
 BECCA 3403.1.1, 3403.1.2, 3403.1.3, 3403.1.4, 3403.1.5, 3403.1.6, 3403.1.7, 3403.1.8, 3403.1.9, 3403.1.10, 3403.1.11, 3403.1.12, 3403.1.13, 3403.1.14, 3403.1.15, 3403.1.16, 3403.1.17, 3403.1.18, 3403.1.19, 3403.1.20, 3403.1.21, 3403.1.22, 3403.1.23, 3403.1.24, 3403.1.25, 3403.1.26, 3403.1.27, 3403.1.28, 3403.1.29, 3403.1.30, 3403.1.31, 3403.1.32, 3403.1.33, 3403.1.34, 3403.1.35, 3403.1.36, 3403.1.37, 3403.1.38, 3403.1.39, 3403.1.40, 3403.1.41, 3403.1.42, 3403.1.43, 3403.1.44, 3403.1.45, 3403.1.46, 3403.1.47, 3403.1.48, 3403.1.49, 3403.1.50, 3403.1.51, 3403.1.52, 3403.1.53, 3403.1.54, 3403.1.55, 3403.1.56, 3403.1.57, 3403.1.58, 3403.1.59, 3403.1.60, 3403.1.61, 3403.1.62, 3403.1.63, 3403.1.64, 3403.1.65, 3403.1.66, 3403.1.67, 3403.1.68, 3403.1.69, 3403.1.70, 3403.1.71, 3403.1.72, 3403.1.73, 3403.1.74, 3403.1.75, 3403.1.76, 3403.1.77, 3403.1.78, 3403.1.79, 3403.1.80, 3403.1.81, 3403.1.82, 3403.1.83, 3403.1.84, 3403.1.85, 3403.1.86, 3403.1.87, 3403.1.88, 3403.1.89, 3403.1.90, 3403.1.91, 3403.1.92, 3403.1.93, 3403.1.94, 3403.1.95, 3403.1.96, 3403.1.97, 3403.1.98, 3403.1.99, 3403.1.100

WARRANTY INFORMATION / TECHNICAL ASSISTANCE

The Warranty of your system begins with the Certified Start-up & Training. This can be done onsite or remotely. Contact BECCA for assistance.

For more information, prices or technical assistance, contact your local BECCA distributor or call / fax our Becca Care™ Numbers:



2010 Cobb International Blvd Suite H
Kennesaw, GA 30152

Tel: (800) 655-5649 **(U.S.A.)**

Fax: (800) 655-5684 **(U.S.A.)**

Copyright © 2003 by BECCA Inc. All Rights Reserved.