



# BECCA®

## INSTRUCTION MANUAL

S800A MANUAL/AUTOMATIC



WORKSTATIONS



- Warranty
- Safety
- Operation

- Service Parts
- Troubleshooting Guide
- Contact Information

# TABLE OF CONTENTS

## PAGE

<b>WARRANTY INFORMATION .....</b>	<b>3</b>
<b>SPRAY GUN CLEANER SPECIFICATIONS .....</b>	<b>4</b>
<b>SAFETY AND WARNING .....</b>	<b>5</b>
General Safety .....	5
Danger and Warning Labels .....	5
General Safety Rules .....	6
Personal Safety .....	6
Unit Use and Care .....	7
Safety Rules .....	7-8
<b>INTRODUCTION .....</b>	<b>9</b>
<b>OPERATION GUIDELINES .....</b>	<b>9-12</b>
<b>TROUBLESHOOTING GUIDE .....</b>	<b>13-14</b>
<b>MAINTENANCE SCHEDULE .....</b>	<b>15</b>
<b>SOLVENTWASH FILTER CHANGE INSTRUCTIONS .....</b>	<b>16</b>
<b>SCHEMATIC OF UNIT .....</b>	<b>17-22</b>
Overall Unit .....	17
Control Head .....	18
Control Head Plumbing .....	19
Wash Basin .....	20
Pump .....	21
Carbon Exhaust Unit .....	22
<b>PARTS DESCRIPTION .....</b>	<b>23-24</b>
<b>OPTIONAL TURBO800 INFORMATION .....</b>	<b>25-26</b>
<b>WARRANTY INFORMATION / TECHNICAL ASSISTANCE .....</b>	<b>27</b>



**LIMITED WARRANTY**  
Solvent Recyclers & Paint Gun Washers

**24 MONTH LIMITED WARRANTY**

**BECCA Solvent Recyclers and Spray Gun Cleaners components are warranted to be free of defects in material or workmanship for 24 months from established purchase date to the original user or from original shipment whichever is sooner. During months 1 through 12 BECCA will repair or replace any component including labor that is found to be defective in material or workmanship as determined by BECCA factory certified service technician. For months 13 through 24 BECCA will furnish parts only (no travel, diagnostic or repair labor is provided) to replace any component that is found to be defective in material or workmanship as determined by BECCA factory certified service technician. In all cases defective parts shall be returned to BECCA for inspection and final approval.**

There is no other express warranty, implied warranties, including those of merchantability and fitness for a particular purpose, are limited to one year from purchase and to the extent permitted by law any and all implied warranties are excluded. This is the exclusive remedy and liability for consequential and incidental damages under any and all warranties are excluded to the extent exclusion is permitted by law.

**CONDITIONS OF WARRANTY**

**BECCA has no control over working conditions, solvents involved in usage and under which purchaser stores, handles or uses BECCA product. We make no warranty or condition, either expressed or implied with respects to usage or mistreatment of product. These warranties apply only to the original purchaser and do not apply if the unit has been misused, subjected to overloading, neglect, accident, altered or used for any other purpose. BECCA shall not be liable for loss, damage or delay due to, without limitation, acts of God, transportation delays, accident, fire, action of civil or military authority, adverse weather or any other causes beyond BECCA's control. This warranty does not cover transportation, interior or exterior finishes. The use of unauthorized chemicals or solvents with acid content in this unit shall render this warranty null and void. BECCA shall not be responsible or liable for any consequential or incidental damages, including without limitation, loss of production or faulty production, loss of use or loss of profit. Attempts at repair or alterations by the owner shall also constitute a violation of this warranty. Only BECCA certified personnel shall start-up, train, repair or alter BECCA equipment. Spray Gun Cleaner Brushes, Filters, and Gun Clips & Solvent Recycler Gaskets/Seals, Oil, and Bags are subject to be replaced due to normal usage, wear and tear within the warranty period and are excluded from this warranty. These warranties replace all other warranties expressed or implied by nature or otherwise, and are not assignable or transferable from original purchaser.**

***Warranty is in effect after receipt of Registration information & full payment***

<b>2010 Cobb International Blvd Ste H Kennesaw, GA 30152 Phone 1-800-655-5649 Fax 1-800-655-5684</b>
--

Revision 1/8/05

## SPRAY GUN CLEANER SPECIFICATIONS

### SPECIFICATION FOR S800A POWER CLEAN™ WORKSTATION SPRAY GUN CLEANER

SPECIFICATIONS	U.S. UNITS	METRIC UNITS
Weight	280 Lbs.	128 Kg
Height	58"	1,450 mm
Width	25"	625 mm
Length	26"	650 mm
Work Table Height	15"	375 mm
Work Table Width	25"	625 mm
Work Table Length	21"	525 mm
Wash Basin Height	13"	325 mm
Wash Basin Depth	20"	300 mm
Wash Basin Width	12"	300 mm
Solvent Capacity of Container (2)	5 Gallons or 10 Gallons (optional)	20 Liters or 40 Liters (optional)
Weight that can be supported by work surface	18 Lbs.	8 Kg
Diameter of Exhaust Duct	6"	150 mm
Air Consumption at 110 psi. / 8 Bar	10-20 CFM	16 – 32 NM <sup>3</sup>
Capacity of Spray Guns per Wash	2	2
Air Supply Operating Pressure	110 psi	7 – 8 Bar
Acoustic Pressure Level LpAm ISO-3746	68.4 dB(A)	68.4 dB(A)
Acoustic Power Level LpAm ISO-3746	79.2 dB(A)	79.2 dB(A)
Ball valves	Brass	Brass
Pump	Dual diaphragm	Dual diaphragm
Pump Capacity (each)	1 Gal/min	4/Liters/min
Groundable containers	2-5 Gal (optional) or 1-10 Gal (optional)	
Outside Frame	Powder paint	Powder Paint
Wash Basin and Work Table	Stainless steel	Stainless steel
Warranty	24 months	24 months

## SAFETY AND WARNING

### GENERAL SAFETY

1. Carefully inspect the shipping carton for any signs of transport damage. The damage to the carton often indicates possibility of transport damage to the equipment inside.
2. Carefully remove your Becca Spray Gun Cleaner from the shipping carton.
3. Check your equipment immediately to ensure that it is free of transport damage. Report any transport damage to the carrier without delay for possible claim procedures. Becca Recycling Technologies Inc. is not responsible for damage to equipment after it leaves our warehouse.
4. Check the equipment list and compare it with the parts you have received. If any parts are missing, contact the supplier you purchased the equipment from.

**Before operating the BECCA SPRAY GUN WASHER, read this Instruction Manual completely. All BECCA products are engineered and manufactured to the highest performance standards and have been subjected to detail testing before shipment from the factory.**

### DANGER AND WARNING LABELS

#### DANGER



1



2



3



4

#### WARNING



5



6



7



8

1. Presence of flammable vapors and solvents.
2. No smoking or metal grinding nearby.
3. Keep away from open flames.
4. Wear Breathable Air during use.

5. Observe warnings at all times.
6. Read the Instruction Manual carefully.
7. Wear solvent-proof rubber gloves.
8. Wear protective eyewear before use.

## SAFETY AND WARNING (cont'd)

### WARNING

« READ ALL INSTRUCTIONS » Failure to follow the SAFETY RULES identified by a BULLET (°) symbol listed BELOW and other safety precautions may result in serious personal injury. « SAVE THESE INSTRUCTIONS »

### GENERAL SAFETY RULES

- ° **KEEP WORK AREA CLEAN.**
- ° **KEEP CHILDREN AWAY.** Do not let visitors come in contact with the equipment. All visitors should be kept away from the work area.

### PERSONAL SAFETY

- ° **GUARD AGAINST ELECTRIC SHOCK.** Prevent body contact with grounded surfaces, for example: pipes, radiators. Solvent resisting rubber gloves and non-skid footwear is recommended where damp or wet ground may be encountered. A ground fault circuit interrupter protected power line must be used for these conditions.
- ° **DRESS PROPERLY.** Do not wear loose clothing or jewelry. They can be caught in the moving parts. Wear protective hair covering to contain long hair.
- ° **USE SAFETY EQUIPMENT. WEAR SAFETY GOGGLES** or glasses with side shields.
- ° **STAY ALERT. USE YOUR COMMON SENSE.** Concentrate on what you are doing. Do not operate the unit when you are tired or under the influence of drugs.
- ° **DO NOT OVERREACH.** Keep proper footing and balance at all times.
- ° **BEFORE CONNECTING THE UNIT** to an air line outlet, be sure the pressure is the same as that specified on the nameplate of the Spray Gun Cleaner. An air line with pressure greater than that specified on the Spray Gun Cleaner can seriously injure the user – as well as damage the Spray Gun Cleaner. If in doubt, **DO NOT** plug in the unit. Using an air line with pressure less than the pressure specified on the nameplate is harmful to the pump.

**UNIT USE AND CARE**

- **DO NOT FORCE THE UNIT.** It will perform better and safer at the rate for which it was designed.
- **THE USE OF ANY OTHER ACCESSORIES** not specified in this manual may create a hazard.
- **DISCONNECT THE UNIT** when not in use, before servicing.
- **DO NOT ALTER OR MISUSE THE UNIT.** These units are precision built. Any alteration or modification not specified is misuse and may result in a dangerous situation.

Only trained repairmen should attempt (°) ALL REPAIRS, electrical or mechanical. Contact the nearest BECCA repair service facility. Use only BECCA replacement parts, any other parts may create a hazard.

**SAFETY RULES**

- **THE OPERATOR MUST WEAR** protective solvent-proof rubber gloves to prevent contact between his hands and the products used for washing.
- **THE OPERATOR MUST WEAR** protective eyewear to prevent spatter from coming in contact with his eyes.
- **THE SPRAY GUN CLEANER** is designed exclusively to wash spray guns and small objects.
- **STAY ALERT** at the start of the wash cycle. Make sure the solvent is not «corrosive». Immediately stop washing and replace the solvent whenever you note signs of corrosion on the worktable.
- **IF EYES COME IN CONTACT WITH SOLVENTS** rinse thoroughly with water.
- **BEFORE USING** the Spray Gun Cleaner, make sure that all safety devices are in perfect operating condition.
- **BECOME FAMILIAR WITH THE CONTROLS** and their functions before commencing work.
- **USE GROUNDABLE CONTAINERS (Containers, solvents are supplied in, are recommended)** for the collection of solvents.
- **BE CAREFUL** when you load or unload the solvent in the unit. Make sure you do not splash or spill the contents on the workshop floor.
- **THE OPERATOR MUST PERIODICALLY** check the level of the dirty solvent contained in the collection pail to prevent it from overflowing.

## SAFETY AND WARNING (cont'd)

- **IT IS STRICTLY FORBIDDEN** to place unsuitable sized object or objects that weigh more than 18 Lbs. / 8 Kg on the work surface of the Spray Gun Cleaner.
- **CLEAN OR REPLACE** the mesh filter periodically.
- **DO NOT USE ELECTRICAL OR PNEUMATICAL TOOLS WITH THE UNIT. AVOID GASEOUS AREAS.** Do not operate portable electric tools in explosive atmospheres in the presence of flammable liquids or gases. Motors in these tools normally spark, and do not scrape or scratch the machine with metal objects; the sparks might ignite fumes.
- **DO NOT ALLOW FAMILIARITY GAINED FROM FREQUENT USE OF YOUR SPRAY GUN WASHER TO BECOME COMMONPLACE.** Always remember that a careless fraction of a second is sufficient to inflict severe injury.
- **DO NOT ALTER OR MISUSE THE UNIT.** Any alteration or modifications is a misuse and may result in serious personal injuries.
- **FIRE EXTINGUISHING SYSTEMS** must be installed in the same room or close to the unit in case of emergency. These appliances must be kept efficient and inspected every year by a certified person.
- **THE INSTALLATION SITE MUST PERMIT PERSONNEL TO EASILY AND QUICKLY MOVE AWAY FROM DANGER ZONES IN CASE OF AN EMERGENCY.**
- **DO NOT USE THE UNIT TO** wash or degrease objects designed to come in contact with food.
- **COMPLY WITH LAWS IN THE COUNTRY** where the Spray Gun Cleaner is installed regarding the use and disposal of the products used to wash clean objects.

THINK SAFETY! SAFETY IS A COMBINATION OF THE OPERATOR'S COMMON SENSE, KNOWLEDGE OF THE SAFETY AND OPERATING INSTRUCTIONS AND ALERTNESS AT ALL TIMES WHEN THE UNIT IS BEING USED.



## INTRODUCTION

This Instruction Manual provides installation, operation and maintenance instructions for the Manual and Hands-Free Spray Gun Cleaner unit. These shall be referred to as Spray Gun Cleaners in the following pages. Spray Gun Cleaners are totally pneumatic units designed for manual washing spray guns and small parts.

It is very practical, time saving and economic for cleaning. The unit is supplied with a pneumatic pump that pulls solvent from the container below in the cabinet. The solvent that you will use will depend on the type of paint that you are using. The manufacturer of the paint will give you the information you need regarding this.

The fumes are exhausted when the operator turns on the "Fume Extractor/POWER CLEAN" dial. The fumes go through the vapor chimney that you will connect to the outside as per local regulations. You have the option of placing an active carbon filter (part #824450). This filter can be installed onto the vapor exhaust duct, which retains contaminating gaseous particles.

This manual is an integral part of the product. It must be properly stored, kept in good condition and available for consultation at any time during the entire working life of the Spray Gun Cleaner. Proper washer operation, economy and durability depend on common sense and compliance with the instructions given in this manual.

## OPERATION GUIDELINES

**Read the following sections carefully. They will help you use your Spray Gun Cleaner correctly and help you select the correct function for your task.**

### Description of the valves

- **a:** "Main Air" supply on and off air valve
- **b:** "Fume Extractor/POWER CLEAN"
- **c:** "Wash Basin"
- **d:** "Manual Wash"
- **e:** "Power Pistol"
- **f:** "Wash Basin Security Valve"

### Description for using the Spray Gun Cleaner unit

- The first step in learning to use the Spray Gun Cleaner is to become familiar with the unit. Operations are carried out via the controls placed on the top front panel which the operator can control the use:
  - a** – The "Main Air Supply" valve controls the air for the Spray Gun Cleaner. This valve should remain closed when not using the Spray Gun Cleaner.
  - b** – The "Fume Extractor/POWER CLEAN™" valve has two (2) functions: giving air to the POWER CLEAN™ connection and opening up the fume extraction system air nozzle for vapor exhaust, and to ensure proper extraction of all harmful vapors when spraying. Solvent vapors are atomized inside the air chamber and conveyed through a special vent plate, Automatically the vapors are pulled by an air nozzles creating a vacuum inside the duct tube.

## OPERATION GUIDELINES (cont'd)

- c - The “Wash Basin” valve allows you to operate the Hands-Free Wash Basin. When engaged the pump will pull solvent through the Filtration System and clean the solvent before discharge.
- d - The “Manual Flow Brush” valve allows you to operate the Manual Flow Brush. When engaged the pump will pull solvent through the Filtration System and clean the solvent before discharged.
- e - The “Power Pistol” valve allows you to operate the POWERPISTOL™. When engaged the pump will pull solvent through the Filtration System and clean the solvent before discharged to clean the Spray Gun.

**IMPORTANT! : DO NOT POUR LEFT OVER PAINT INTO THE WASH BASIN OR THE MANUAL SIDE OF THE CLEANER.**

### Manual Cleaning

- To manually wash your spray guns start by removing the cup from the spray gun, empty the cup's residues into a separate pail. Pour approximately ½ inch of used solvent by turning the “Manual Brush Wash” valve (d) to the **ON** position into cup and clean with the brush.
- This solvent is returned into the solvent container for reuse through the filtration.
- A brush has been added to the unit to help clean parts and paint guns. The solvent will come out from the center of the brush.
- You can also clean parts or spray guns with “Power Pistol” valve (e). When turning this valve on the POWERPISTOL™ will be activated helping to clean hard to reach areas.

### Hands Free “Wash Basin” Cleaning

- You can wash two (2) paint guns and their accessories simultaneously. The first step is to install the trigger clip on the spray gun. Start by pulling the trigger backward and install the clip (34) on the trigger. The gun trigger must remain open. If you use a suction feed gun install it on nozzle (33), or if you use a gravity gun insert it on nozzle (33).
- Close the washing basin door and turn on the Security Valve. Then turn the “Wash Basin” valve (c) to the **ON** position. It can remain in this position as long as you like since we are re-circulating the solvent through our filtration system.
- Never open the cover when the unit is washing. Wait until you have put the “Wash Basin” valve (c) to the off position. Then you can turn off the security valve and open the cover.

### In case of inadequate exhaust air movement

- Check the air inlet and the compressed air pressure.
- Clean the air inlet filter located inside the washer head.
- Clean or replace the mesh filter and make sure that it is positioned below the vapor evacuation duct.
- Check and clean the evacuation nozzles located at the base of the duct.

Check that the vapors evacuation duct is perfectly vertical for at least 4 feet or 2 meters

### **OPTIONAL Filtration System**

The unit has an Optional Filtration Recycling System to remove particulate from the solvent. This system filters out particulate down to 25 micron. There is a 2 stage combination system of 75 micron for gross residues and a final of 25 micron for the fine residues. Some processes may require the solvent to be purged periodically due to a build up of activate type solvents.

The Filters are easily changed by a replacement kit (825244K) that includes one 75 micron filter, one 25 micron filter and two seals (seals are normally useless once the housing is opened).

### **Hose Cleaner (option)**

- If the unit comes with a hose cleaner you will need to place an extra pail in the unit. On the left side of the unit under the valve system you will find two (2) ¼ inch fittings. Place one (1) safety coupler attachment on each fitting that will work with our hose systems. Then you will be able to connect the hose to be cleaned.

How to clean the hose:

- Open valve (f) to the used solvent side and let it clean for a few minutes.
- Turn valve (f) to the clean side for 15 to 30 seconds to let clean solvent drain through the hose completely.
- - Finally, open valve (e). This valve will remove all the solvents left inside the hose. It will take approximately 60 seconds to dry the hose. The hose is now ready to be re-used.

### **Solvent Transfer System**

- When the **USED SOLVENT** container has been used for several washings, it has to be transferred into the **SOLVENT SAVER™ Recycler** to be recycled. **Open** the **loading valve** located on the recycler. The pump will transfer the used solvent from the gun washer pail to the recycler. Stop when the solvent level in the boiler is about ½ inch below the bag-retaining ring. **Do not overfill.**

For instructions pertaining to the recycling of solvent refer to the **SOLVENT SAVER™ Recycler** Instruction Manual.

When the **CLEAN SOLVENT** container becomes empty, exchange it with the one in the recycler compartment. Starting the distillation cycle will refill the pail again and again.

### **Identification of the Spray Gun Cleaner**

Every spray gun cleaner has an identification plate inside the door that indicates:

- Manufacturer brand
- Manufacturer name and address
- Spray Gun Cleaner model and serial number

Information on this identification plate must always be specified when asking for service and/or spare parts.

**Periodical check and maintenance**

Please follow the rules and regulations listed below to safely maintain the Spray Gun Cleaner:

- Periodically make sure that safety devices are complete and efficient.
- Periodically replace the mesh filter.
- Periodically clean the working surface and the cover from any eventual deposits.
- It is strictly forbidden to remove or tamper with safety devices.
- According to the instructions given in this manual, only qualified and specialized personnel must perform maintenance on the Spray Gun Cleaner.
- Disconnect the compressed air supply when it is necessary to repair or perform maintenance on the appliance.
- Maintenance must be performed carefully, following the instructions given in this manual for replacing damaged or worn parts.
- The symbolic labels attached to the Spray Gun Cleaner give clear guidelines for preventing accidents. These labels must always be kept clean and immediately replaced if they are even partially removed or damaged. It is strictly forbidden to operate the Spray Gun Cleaner when even only one of these symbolic labels is missing from the point where the Manufacturer placed it.
- Always use **BECCA GENUINE REPLACEMENT PARTS** during repair and maintenance.

## TROUBLESHOOTING GUIDE

PROBLEM	CAUSE	SOLUTION
Pump is not operating	<ul style="list-style-type: none"> <li>- Main Air is not on.</li> <li>- Air gage shows less than 40 psi.</li>   <li>- No sound coming from pump.</li>   <li>- Pump is pumping but no solvent is flowing.</li> </ul>	<ul style="list-style-type: none"> <li>- Turn on Main Air</li> <li>- Make sure air gage is operating correctly. Adjust pressure.</li> <li>- Pump should be replaced – possible broken actuator spring</li> <li>- Review solvent lines to assure they are in the containers Make sure containers have solvent Make sure the Control Valves are operating. Look for solvent flowing through the lines. Look for aeration in lines – There is a leak somewhere</li> </ul>
Pump is very slow	<ul style="list-style-type: none"> <li>- Sluggish or sporadic.</li> </ul>	<ul style="list-style-type: none"> <li>- Make sure air gage is not jumping Around or below 40 psi.</li> <li>- Look for aeration in lines – There is a leak somewhere.</li> <li>- Assure the Strainer is not clogged</li> </ul>
Pump is very fast	<ul style="list-style-type: none"> <li>- Accelerated pumping sound</li> </ul>	<ul style="list-style-type: none"> <li>- Make sure containers have solvent</li> <li>- Check for bad connections on the suction side of the pump</li> </ul>
Fume smell coming from the unit.	<ul style="list-style-type: none"> <li>- Fume Extractor Valve is in the ON position and air is <u>not</u> flowing.</li>   <li>- Fume Extractor is ON and air is flowing but not pulling fumes</li> </ul>	<ul style="list-style-type: none"> <li>- Open the cover to assure the blue air line is attached. Check for leaks in the blue air lines Check to assure valve is operational</li> <li>- Check exhaust filter. It may need replaced Review exhaust path for obstruction</li> </ul>
Solvent is not flowing the valve is operated	<ul style="list-style-type: none"> <li>- Pump is not operating.</li> <li>- Pump is operating and nothing is flowing.</li> </ul>	<ul style="list-style-type: none"> <li>- See “Pump not Operating” section.</li> <li>- Check to see if flow is working for either USED or CLEAN – If both are not and pumps are pumping review the valve. If one is working and the other is not review the Pump not Operating” section.</li> </ul>
Manual Spray Nozzle is not operating.	<ul style="list-style-type: none"> <li>- The Pump is not Operating</li>   <li>- Manual Spray Nozzle is clogged.</li> </ul>	<ul style="list-style-type: none"> <li>- See “Pump not Operating” section</li> <li>- Check the nozzle by removing and blowing out debris (reverse direction)</li> </ul>

## SOLVENTWASH TROUBLESHOOTING GUIDE

PROBLEM	CAUSE	SOLUTION
Diminished Fluid Flow	Filters are almost loaded	Change filter(s) – either the 75 micron filter or both filters, depending on the filter change schedule (see instructions with Replacement Filter Kit)
Rapid Pump Acceleration with little to no fluid flow	Filters are loaded	Make sure containers have fluid.  Change filter(s) – either the 75 micron filter or both filters, depending on the filter change schedule (see instructions with Replacement Filter Kit)
Rapid Pump Acceleration After recent filter change	Air is getting into the fluid lines	Check the filter canisters – make sure they are screwed on snugly (hand tightened)  Check the seals in the filter canisters – make sure they are seated correctly  Make sure new seals were installed with the new filters
No fluid flow, loud air noise coming from pump	Air is by-passing to exhaust in the pump	Replace the pump
No fluid flow, no pump noise	The Pump is not Operating	Replace the pump

**Troubleshooting method to isolate the system (Pump) from the Filtration Recycling Systems:**

Remove filters from housings, re-attach empty housings and run the gun cleaner (it will take several minutes for the housings to fill up). If the system runs normally, the problem was caused by the filters. If the system does not run correctly, the problem was caused by the pump.

**Consumable Replacement Parts:**

**Solvent & Waterborne (ENVIRO) Models:**

825159 – Splash Pad for 700 & 800 Models      825165 – Splash Pad (100 Series Models)  
 825162 – Basin Splash Pad for 50 Models      825163 – Back Splash Pad (50 Series Models)  
 825258K – Filtration Recycling System Cartridge Replacement Kit (50 & 100 Series Models)

**Solvent Models Only:**

825244K – Filtration Recycling System Cartridge Replacement Kit (Solvent – Not 50 or 100 Series)

## MAINTENANCE SCHEDULE



### Each day

- Wipe-down the unit with solvent. The paint and decals are solvent resistant.
- Remove any contaminants from the bottom of the Grill

### Every 3 - 4 Months

- Replace Filter Cartridges. This is the typical time frame for most operations.

### Semi-Annually

- Change out "Used Solvent" Container.
- Replace filter (824588) in back panel.
- Replace Extractor/Dryer Compressed air filters (824016)
- Replace BECCA Protect™ Maintenance Coating (ECP 831004)
- Review Ground Clamp (823079)

### Annually

- Replace Manual Flow Brush (824610)
- Review & Replace illegible or damaged Decals

# SOLVENTWASH™

## Filtration Recycling System (Optional)

### Filter Replacement Instructions

1. **Important!** Before removing the Filter Housing:  
Lift the line out of the container  
Then allow the pump to continue to run with the Wash Basin or Flow Brush in the “On” position.  
Run the unit to remove some of the solvent from the Housings (3-5”).
2. Turn the Filter Housing with the provided Wrench. If stuck, lightly tap housing with a rubber mallet to break the seal. Care should be taken so not to crack the housing.
3. Make sure to replace both filters and place them in the correct position (75 Micron- first to see the solvent and 25 Micron – last to see the solvent before being used)
4. Make sure to replace both seals in the Filter Housings. (Note: The old seal will not work after the Filter Housing has been removed)
5. Make sure Filter is located in the Guide located on the threaded top before spinning housing. Tighten The Filter Housings to a snug position. (Do Not Over Tighten!!)
6. When Running the Spray Gun Cleaner it will take a few minutes to fill the Filter Housing before flowing out of the selected function.
7. Used Filters (are Hazardous until proven different) should be allowed to dry and then dispose per local jurisdiction requirements.

**You are ready to use your system!**



**SCHEMATIC OF UNIT**  
**SCHEMATIC OF UNIT (cont'd)**

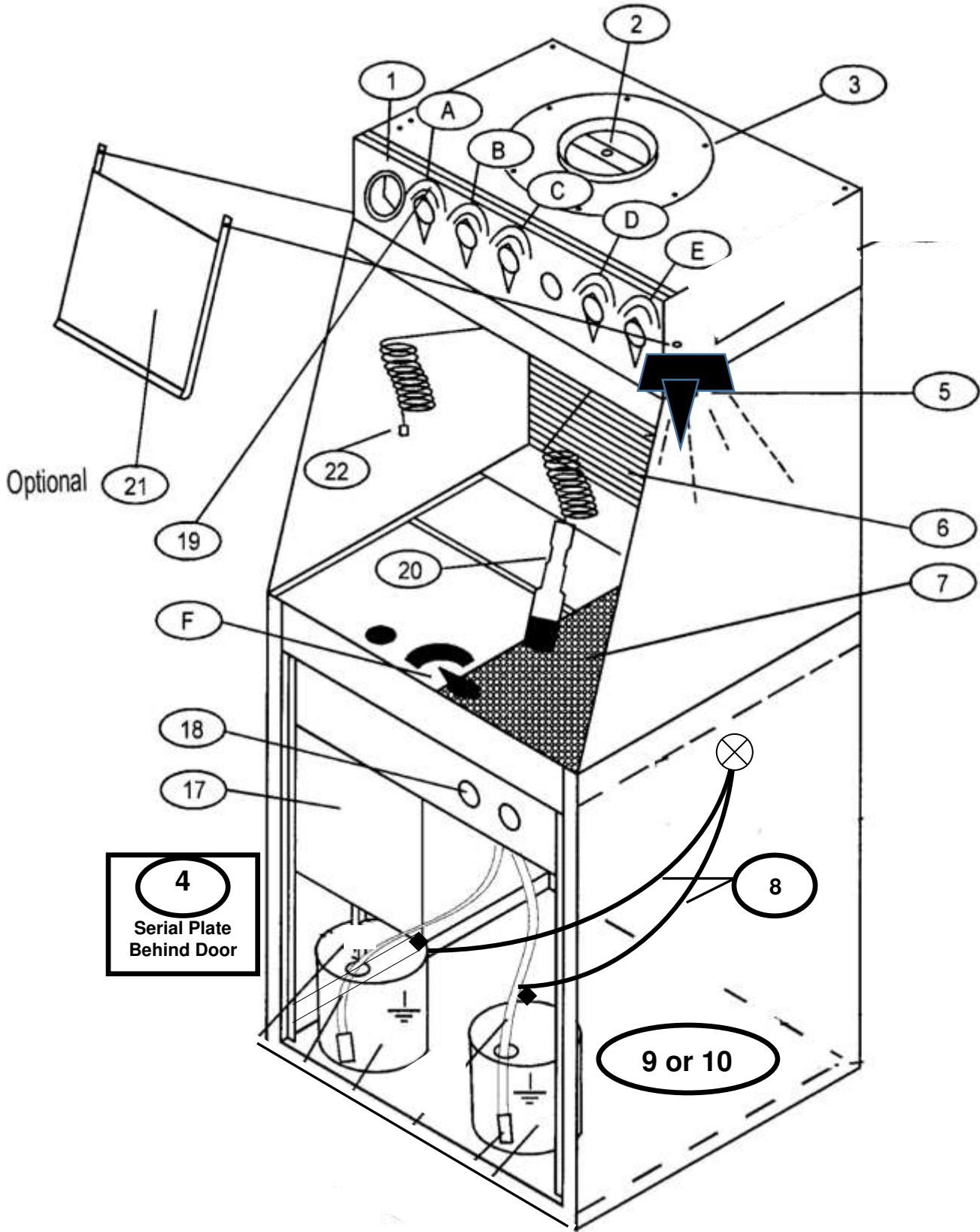

SCHMATIC OF UNIT (cont'd)

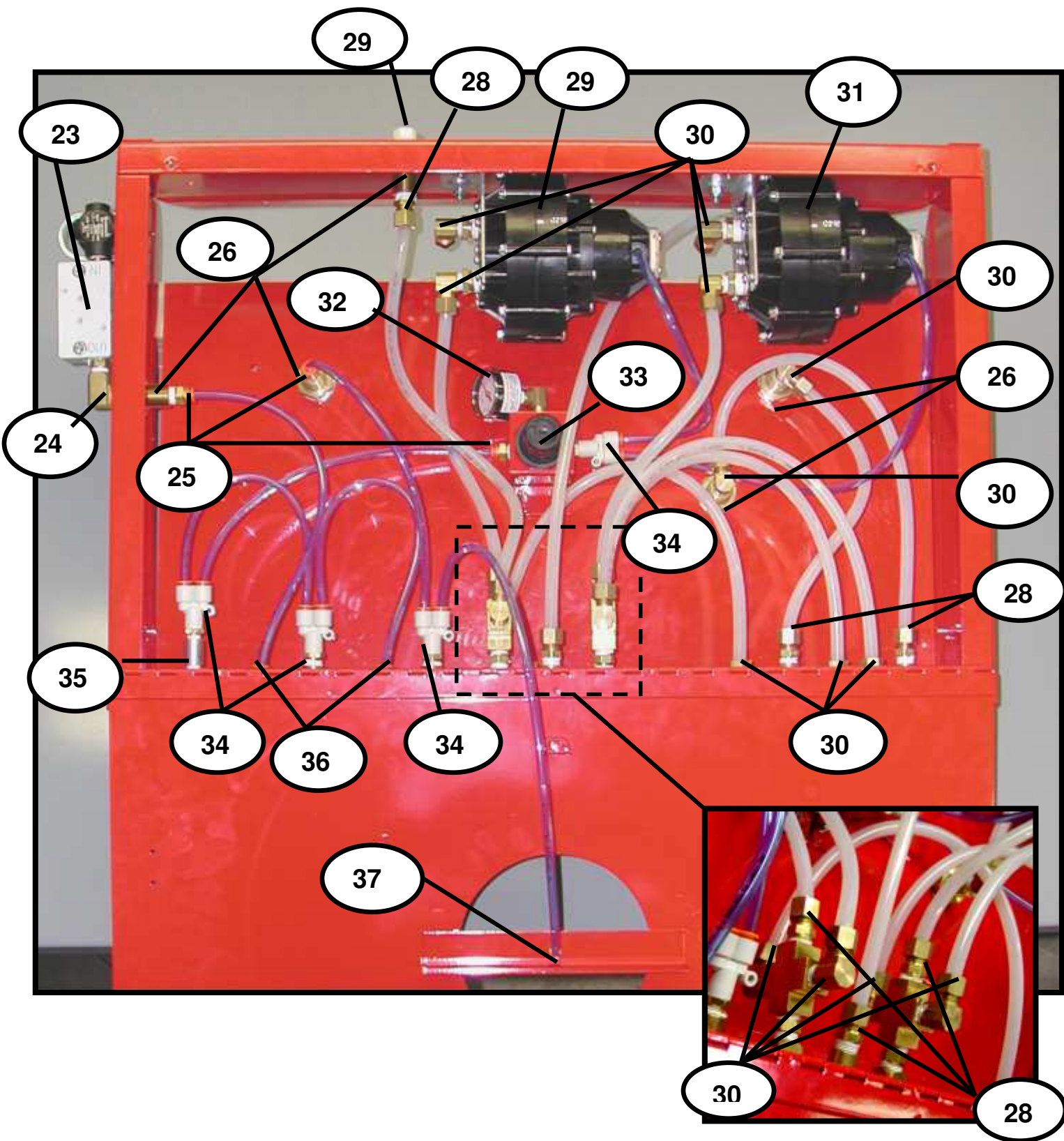

**SCHEMATIC OF UNIT (cont'd)**

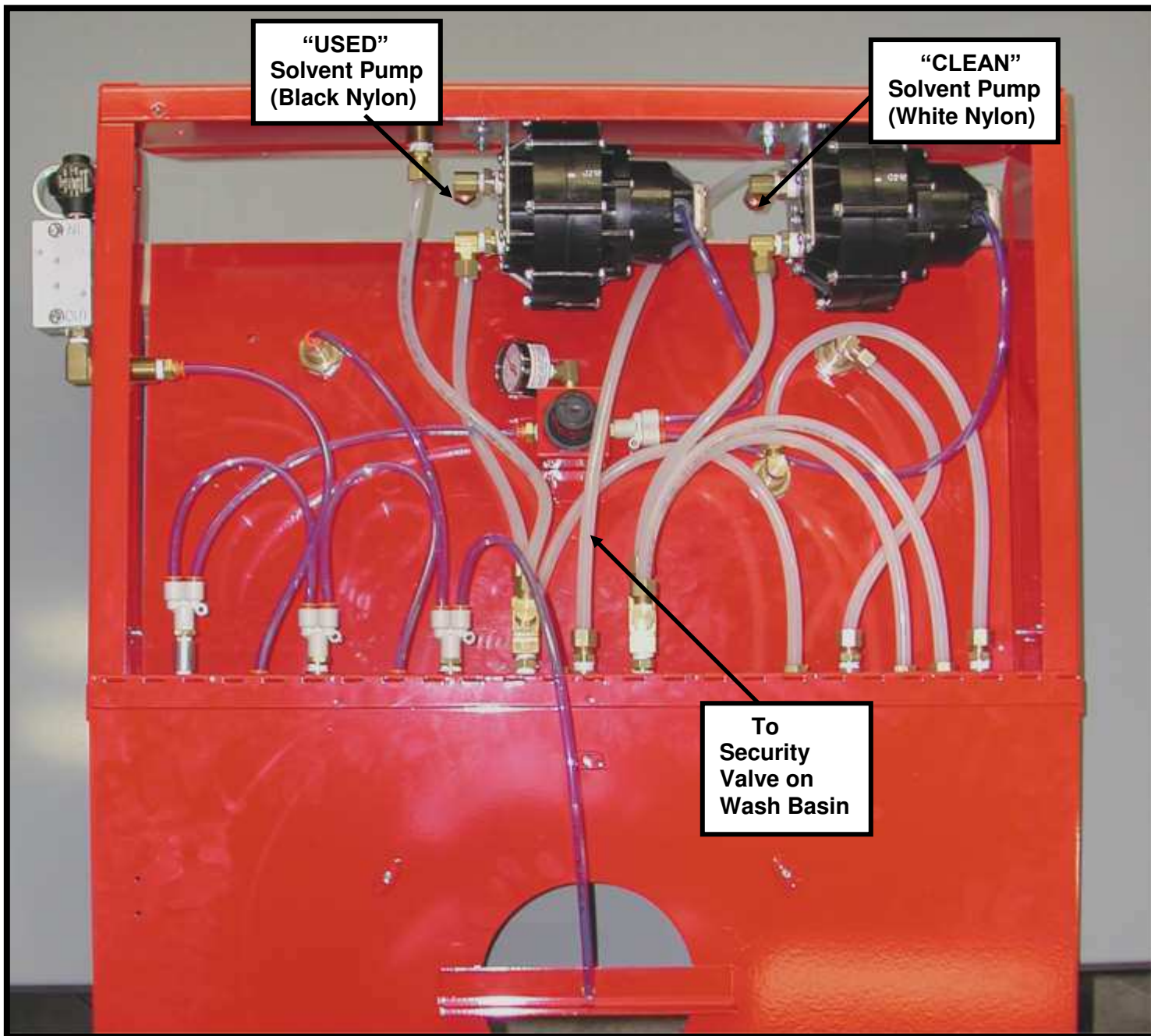

**LEGEND**

 Air - Blue Polyurethane Tube

 Solvent - White or Black Nylon Tube

**Nylon Tube**

**SCHEMATIC OF UNIT (cont'd)**

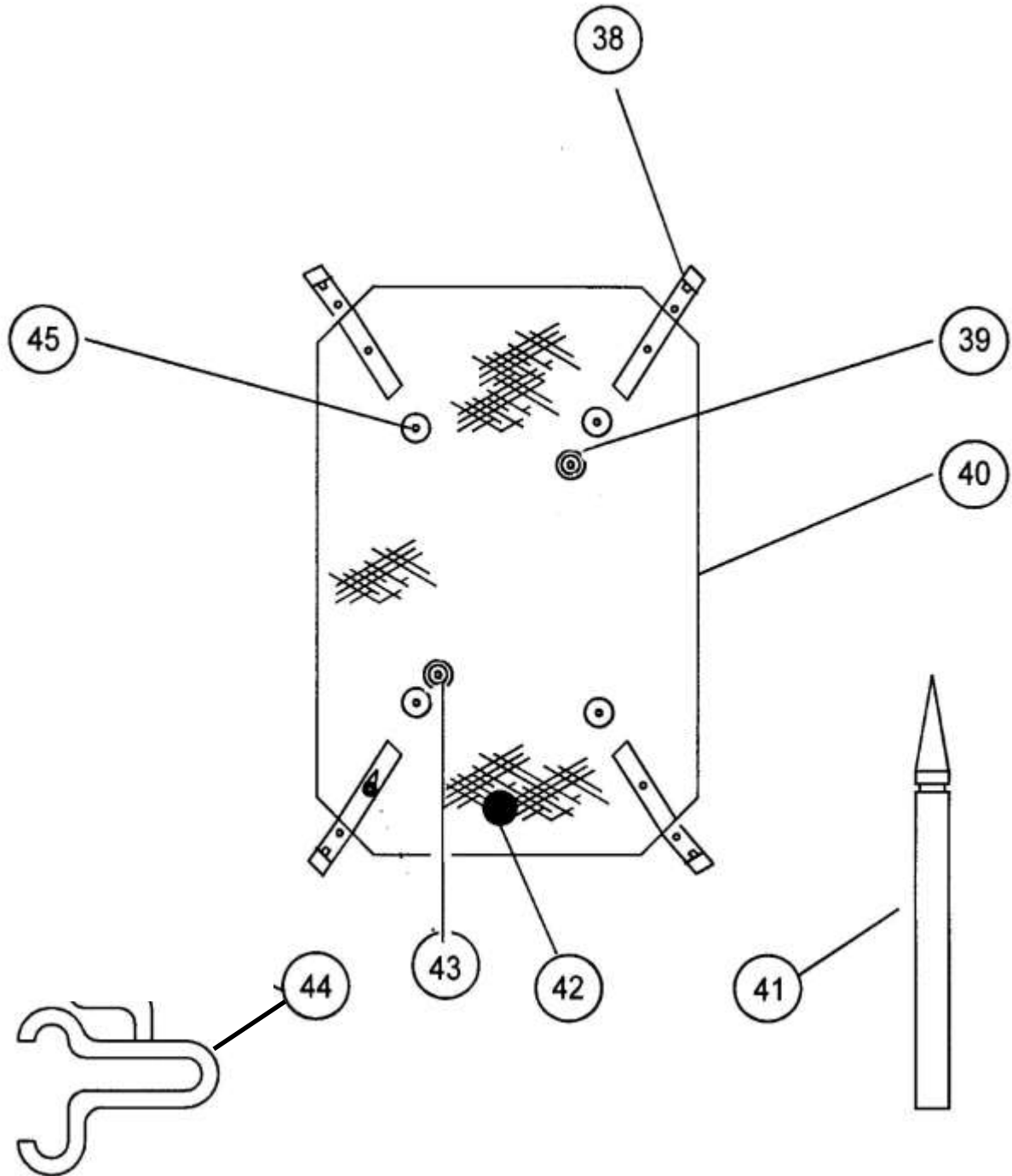

**SCHEMATIC OF UNIT (cont'd)**



**SCHEMATIC OF UNIT (cont'd)**

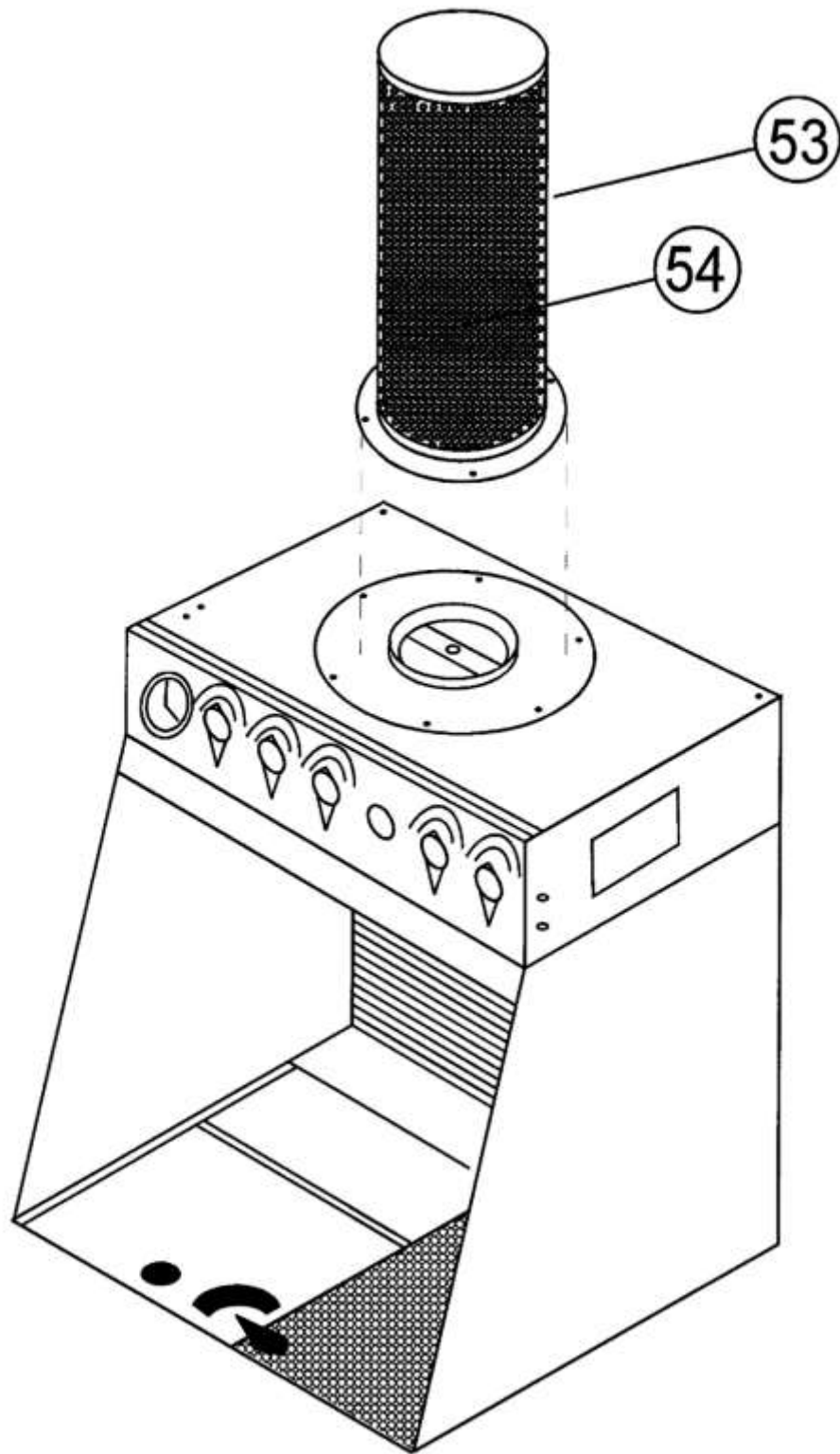

**PARTS DESCRIPTION**

<b>INDEX</b>	<b>PART #</b>	<b>DESCRIPTION</b>	<b>QUANTITY</b>
A	824552	MAIN AIR VALVE 2-WAY VALVE	1
B	824552	FUME EXTRACTOR VALVE 2-WAY VALVE	1
C	824547	WASH BASIN CLEAN OR USED 3-WAY VALVE	1
D	824547	MANUAL BRUSH WASH 3-WAY VALVE	1
E	824552	POWER PISTOL 2-WAY VALVE	1
F	824552	WASH BASIN SECURITY 2-WAY VALVE	1
1	824014	PANEL MOUNT GAGE	1
2	823152	AIR JET FITTING (823152) & NUT (823115)	1
3	823114	10-32 SCREW	MULTIPLE LOCATIONS
4	831165	SERIAL PLATE	1
5	825201K	POWER PISTOL (MOUNTED)	1
6	824588K	FILTER 20 X 25 (2)	1
7	830125	9880 MANUAL GRILL	1
8	823579	GROUND CLAMP KIT	1
9	823200	5 Gallon Solvent Cans (Metal for Organic Solvents)	1
10	830107K Optional	10 Gallon Stainless Steel Tanks	1
11	823422 Optional	5 Gallon H2O Container (Plastic for H2O)	1
12	824624	STRAINER	2
13	824512K	WHITE NYLON TUBING – 25'	1
16	823163	BARB FITTING	1
17		BASIN TANK	1
18	TURBO800 Optional	HOSE CLEANER SYSTEM	1
19	831128K	DECAL KIT FOR 9870, 9880, NEXT 700 & 800	1
20	824611K	FLOW BRUSH & COIL HOSE ASSY	1
21	830128 OPTIONAL	OPTIONAL COVER DOOR	1
22	824609	RED COIL HOSE	1
23	824013K	2-STAGE FILTER/REGULATOR	1
24	823111	ELBOW	1
25	824558	PUSH-IN FITTING	MULTIPLE LOCATIONS
26	824632	BULKHEAD FITTING	MULTIPLE LOCATIONS
27	823017	PLUG	1
28	823130	COMPRESSION FITTING	MULTIPLE LOCATIONS
29	811021	USED SOLVENT PUMP	1
30	823131	90° COMPRESSION FITTING	MULTIPLE LOCATIONS
31	811021	CLEAN SOLVENT PUMP	1
32	824561	PRESSURE GAGE	1
33	824562	REGULATOR	1

**PARTS DESCRIPTION (cont'd)**

INDEX	PART #	DESCRIPTION	QUANTITY
34	824557	"Y" PUSH-IN FITTING	MULTIPLE LOCATIONS
35	824014	PRESSURE GAGE	1
36	824560	90° PUSH-IN FITTING	MULTIPLE LOCATIONS
37	823152	PUSH-IN FITTING	1
38	825015	SPRAY MANIFOLD FOR WASH BASIN	1
39 & 43	824589	SPRAY GUN MOUNT NOZZLE	2
40	830124	WASH BASIN GRILL	1
41	824623K Optional	OPTIONAL CUP GUN EXTENSION TUBE & NOZZLE	1
42	823102	GRILL KNOB – PLASTIC	1
44	825053K	METAL TRIGGER CLIP KIT	1
45	824554	SPRAY NOZZLE	12
46	811021	PUMP	1
47	811021R	REBUILT PUMP (If Available)	
53	824450 Optional	OPTIONAL CARBON EXHAUST UNIT	1
54	824450B	CHARCOAL MATERIAL – 55 LB BAG	1
		<b><u>OPTIONAL ACCESSORIES</u></b>	
	831004	BECCA PROTECT FILM 30" x 200' Roll – PEEL AWAY FILM	
	832800K	Decal Kit for S800A	
	825244K	SOLVENT FILTER REPLACEMENT KIT (Incl 1-75m & 1-25m Filters & (2) seals)	



Read the following sections carefully. They will help you use your Hose Cleaner Option correctly and help you select the correct function for your task.

Description of the valves



- **g**: “Fume Extractor”/”POWER CLEAN”/TURBO CLEAN On/Off
- **h**: “Hose Cleaner”

Description for using “Hose Cleaner”

- The first step in learning to use the Hose Cleaner is to become familiar with the unit. The Hose Cleaner consists of two (2) Ports located under the Hood Enclosure (Here you can place your preferred “Quick Disconnects” for the Hose attachment.) and two (2) controls on the face panel:



**g** – This feature provides “POWER CLEAN” (Compressed air strategically mixed with the solvent) to the Hose cleaning process, as well as it will purge the solvents from the lines at the end of the process.

**h** – This valve initiates the Hose Cleaner .



**SCHEMATIC TURBO S800A**

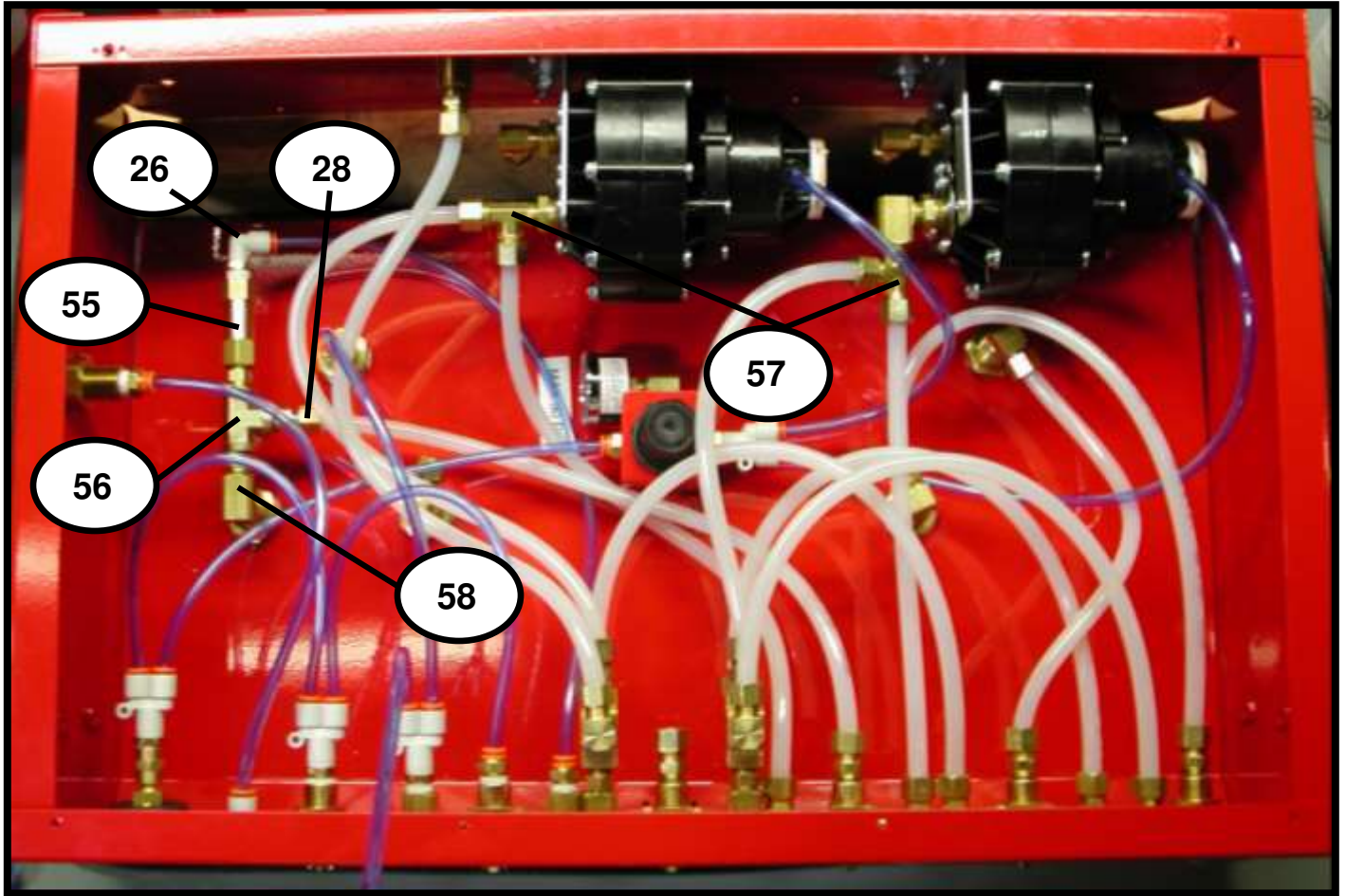

**PARTS DESCRIPTION**

INDEX	PART #	DESCRIPTION	QUANTITY
G	824547	FUME EXTRACTOR/HOSE AIR PURGE VALVE	1
H	824547	HOSE CLEANER USED/CLEAN SOLV VALVE	1
55	824636	CHECK VALVE	1
56	824637	1/4 » NPT FEMALE "T"	1
57	823134	1/4" NPT x 3/8" TUBE "T"	2
58	824556	FLOW CONTROL	1
All Other #'s		SEE MAIN SCHEMATIC	

The Warranty of your system begins with the Certified Start-up by your local BECCA Distributor. Make sure this is completed and you receive a copy of the Certified Start-up document.

For more information, prices or technical assistance, contact your local BECCA distributor or call / fax our BECCA Care™ Numbers:



2010 Cobb International Blvd Ste H  
Kennesaw, GA 30152

Tel: (800) 655-5649

Fax: (800) 655-5684

Copyright © 2008 by BECCA Inc. All Rights Reserved.